

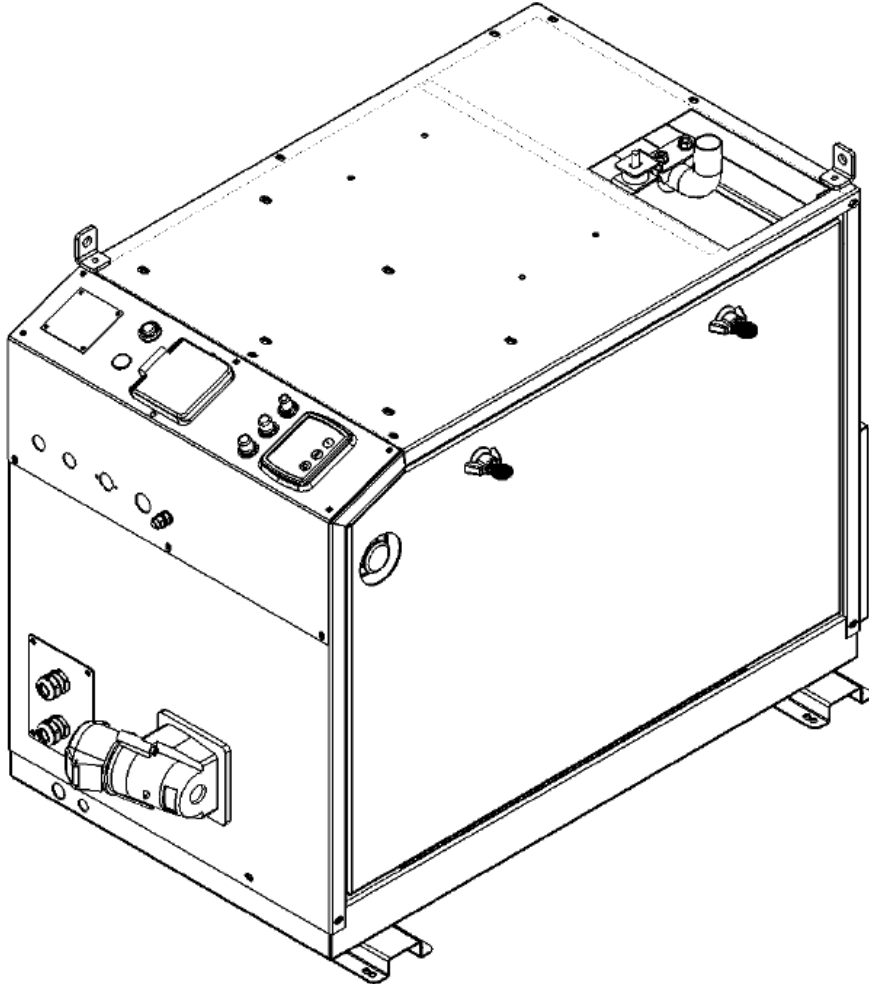

SSD6000W2 Handbook Deep Sea 3110



**DO NOT OPERATE THE GENERATOR BEFORE READING THIS MANUAL AND ENGINE
MANUFACTURER'S OWNER'S MANUAL AND WARNINGS.**

**THIS STEPHILL GENERATOR HAS BEEN DESIGNED TO PROVIDE SAFE AND EFFICIENT SERVICE
IF OPERATED AND MAINTAINED CORRECTLY.**

**MANY ACCIDENTS OCCUR THROUGH FAILURE TO ADHERE TO FUNDAMENTAL SAFETY
PROCEDURES.**

Contents

	Page
1 SPECIFICATION	1
2 GENERAL SAFETY	1
2.1 Warning signs	1
2.2 Safety hazards	1
3 POTENTIAL HAZARDS	1
3.1 Auxiliary power	1-2
3.2 Operating environment	2
3.3 Temperature range	2
3.4 Reference relative humidity	2
3.5 Reference barometric pressure	2
3.6 Flammable environment	2
3.7 Saline environment	2
4 SAFETY CONSIDERATIONS	2
4.1 General	2
4.2 Fuel	2
4.3 Lubricating oil	2
4.4 Safe lifting	2
4.5 Earth connection	3
4.6 Fumes	3
4.7 Noise	3
4.8 Battery acid	3
4.9 Fire	3
4.10 Hot parts	3
5 OPERATING INSTRUCTIONS	3
5.1 Pre-Start checks	3
5.2 Warning	3
5.3 Control panel	3
5.4 Long term storage	4
5.5 Fuel system bleeding procedure	4
6.0 DEEP SEA 3110 OPERATING INSTRUCTIONS	4
6.1 Description of controls	4
6.2 Starting the engine	4
6.3 Remote start panel operation	5
6.4 Starting sequence	5
6.5 Engine running	5
6.6 Stopping the engine	5
6.7 Automatic operation	5
6.8 Waiting in auto mode	5
6.9 Viewing the instruments	5
6.10 Fault icons	6
6.11 Fault finding 3110	6-7
6.12 Fault finding general	7-8
7 SERVICE AND MAINTENANCE	8
7.1 Removal instructions for SSD6000W2	9-10
7.1 Engine service	10
7.2 Alternator service	10
8 MECCALTE ALTERNATOR SPARES	10
9 YANMAR CONSUMABLE SPARES	10
10 GENERAL SPARES	10-11
11 WARRANTY	11
SSD6000W2 Exploded view	12
SSD6000W2 Duct exploded view	13
SSD6000W2 230V 32A Socket MCB RCD	14
SSD6000W2 L100 Deep sea 3110 wiring diagram	15

1 Specification

	SSD6000W2
kVA	6.0
kW	4.8
LWA	79
dBA@7M	54
Engine	Yanmar L100
Alternator	Meccalte S20W - 95
Voltage	230v
Weight	178Kg
Length	865mm
Width	530mm
Height	700mm

2 General Safety

2.1 Warning signs

Warnings shown on the machine should be observed at all times. The warning signs should be checked for legibility and any that have become damaged should be replaced. The following are shown on the generator:

WARNING

BEFORE STARTING.

- **READ HANDBOOK AND SAFETY ADVICE**
- **CHECK OIL LEVEL**
- **DO NOT ADJUST ENGINE SPEED WITHOUT SUITABLE TEST EQUIPMENT**



**RISK OF ELECTRIC SHOCK
ALWAYS TURN OFF GENERATOR
BEFORE OPENING. KEEP
CLOSED AT ALL OTHER TIMES**



**CAUTION
HOT EXHAUST**

2.2 Safety hazards

Do not climb on the generator, as dents may cause overheating of the acoustic lining. It is important to keep the generator clean and well serviced, in particular keep all air vents / louvers clear of debris to prevent poor performance or possible overheating and permanent damage to the generator.

Keep well clear of moving parts on the generator at all times.

Children and pets must be kept clear of the operating area.

3 Potential Hazards



3.1 Auxiliary power

The electricity produced by an engine driven Generator is very similar to mains electricity and should be treated accordingly.

Do not remove covers and attempt to work on the Generator while the engine is running.

Check the rating and electrical safety of the load before connecting the Generator.

Equipment should never be connected that in total exceeds the specified rating of the Generator.

Installation of the generator as a standby or secondary power source should only be undertaken by a fully qualified electrician using the appropriate means of isolation from the mains supply. Installation must comply with all applicable laws and electrical codes.

3.2 Operating Environment

The Generator should always be operated on level ground.

3.3 Temperature Range

A temperature range between -10°C and +35°C are the normal limits of operation. Operating outside the range will require additional modifications.

3.4 Reference Relative Humidity

The standard reference condition for relative humidity is 30%. Above this value the rated power must be reduced.

3.5 Reference Barometric Pressure

The standard reference condition for total barometric pressure is 1 bar.

This corresponds to an altitude of approximately 100m. Above 100m the rated power must be reduced.

3.6 Flammable Environment

Stephill Generators must not be used in a flammable environment.

3.7 Saline Environment

Operation of the machine in a saline environment will require additional corrosion protection.

4 Safety Considerations



4.1 General

All Stephill Generators comply with all the current EEC directives including:
2006/42/EC Machinery Directive
2000/14/EC Noise Emission in the Environment by Equipment for use Outdoors
2004/108/EC EMC Directive
2006/95/EC Low Voltage Directive

4.2 Fuel

Fuels and lubricants are a potential source of fire. Lubricants in particular used engine oil, are potentially carcinogenic. Direct contact should always be avoided by wearing suitable rubber gloves when handling them. Be careful not to spill fuel, clean up any spillages. Inhalation or swallowing of Diesel should be avoided. If in doubt seek medical advice. All other forms of contact are irritant and therefore should also be avoided. If skin contact is made wash with soap and water.

4.3 Lubricating Oil

New oil presents no hazard following short term exposure.

Used oil should not be allowed to contact the skin. If this does occur, wash off quickly with a proprietary hand cleanser.

4.4 Safe Lifting

Where mechanical assistance is used in lifting machines, ensure the lifting eye is used, and that all components used to lift the machine are within their Safe Working Load (SWL).

The integral lifting beam and associated lifting eye on the generator should be regularly checked for signs of damage or gross corrosion.

All Nuts and Bolts associated with the lifting beam should be regularly checked for tightness and corrosion.

Lifting equipment should not be attached directly to the Engine/Alternator except for lifting of Engine/Alternator only.

4.5 Earth connection

All Stephill products are fitted with an earth stud on the control panel this must be connected to an earthing system or spike. Any earth spike required is dependant on the local conditions of use. The size is determined by reference to current IEE regulations or to a competent electrician.

4.6 Fumes

Make sure that the Generator is at least 2 metres away from any building during operation. Operate in a well ventilated unconfined area, so that fumes can be properly dispersed. Silencer outlet should be facing an open area to prevent fumes being recirculated. There is the danger of asphyxiation due to exhaust gases. Inhalation of poisonous exhaust fumes can lead to serious injury or death. The generator must not be used in a poorly ventilated or enclosed area.

4.7 Noise

Ear protection may be required depending on the combined noise level of the Generator, auxiliary load and the operator's distance from it and the length of exposure. (Noise at Work Regulations 1989)

4.8 Battery Acid

This is corrosive and irritant by all forms of exposure. Direct contact should always be avoided by wearing suitable rubber gloves, some form of eye protection should also be used. If skin contact is made wash with clean water.

4.9 Fire

Ensure that suitable fire extinguishers (AFFF or CO₂) are kept within proximity to the generator. Do not cover, enclose, or obstruct the airflow to the generator during or shortly after use, due to fire hazard or damage to the generator from overheating. Allow the generator to cool after use before storing away. Keep all inflammable objects clear of the Generator.

4.10 Hot parts

There is the danger of burns as parts of the generator will become very hot during use. No part of the engine, alternator or exhaust must be touched during or shortly after operation. Do not operate the generator unless all guards are in place. There is a risk of burns or serious personal injury.

5 Operating instructions

5.1 Pre-start checks

Before starting the generator please read the Yanmar engine owner's manual.

Check Fuel & Oil level before attempting to start.

This engine is equipped with an oil and temperature switch and will shut-down for low oil pressure and high engine temperature.

If engine runs out of fuel do not attempt to start before priming. Press fuel pump prime button for 20-30 seconds. The engine should then self-bleed and start when you go through the starting procedure.

5.2 Warning

Do not operate the changeover switch with load connected.

Always switch load off before disconnecting plugs.

To switch power off at Generator always use circuit breaker.

5.3 Control panel

The control panel has an emergency stop which is only for emergency use.

This generator is equipped with an RCD.

Ensure load is switched off before starting generator.

Always turn load off before stopping generator.

5.4 Long term storage

For storage or long periods of inactivity, Stephill Generators recommend the following:

Generators should be stored with oil filled to the correct capacity & battery disconnected; Storage periods of 18 months and over may require special lubricants and treatments. If so please seek further advice from the engine manufacturer.

Before the generator is used after long term storage, all fuels and oils should be replaced.

Generator mounts, pipes and hoses should be checked to ensure that they are un-perished following extended periods of storage.

The generator should be stored in a clean dry area, ideally having a reasonable constant ambient temperature, and ideally not below freezing.

5.5 Fuel system bleeding procedure

A self-bleeding system is fitted to these generators; the engine should not need bleeding unless maintenance has been carried out.

1. Loosen the injector pipe fitting (17mm nut) on the fuel pump, move to one side leaving the delivery valve holder (black male fitting) on the fuel pump exposed.
2. Loosen the Delivery valve holder (17mm nut) but only by 2 complete turns.
3. Press fuel pump prime button until all the air has escaped from the delivery valve holder, and diesel starts to trickle out.
4. Then tighten the Delivery valve holder and the injector pipe fitting. Operation complete.

Delivery valve holder

Injector pipe fitting



6 DEEP SEA 3110 OPERATING INSTRUCTIONS

6.1 Description of controls

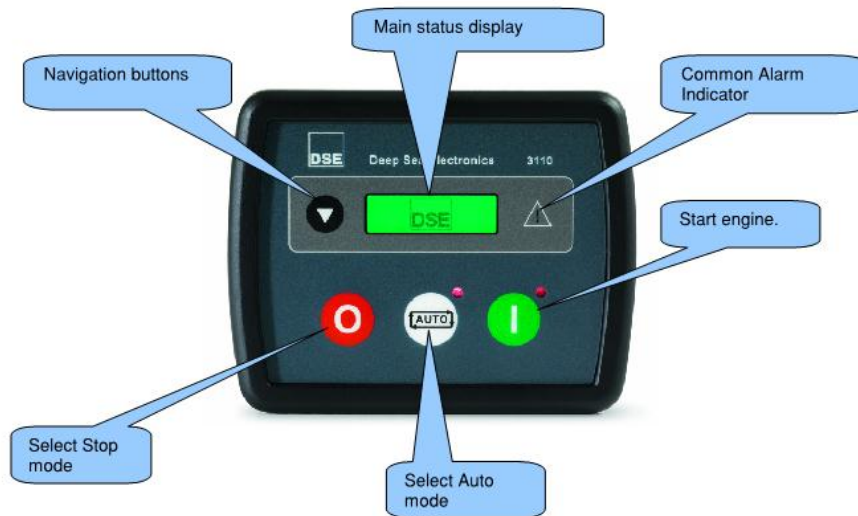

6.2 Starting the engine

To begin the starting sequence, press the  button.

The  icon is displayed to indicate Manual mode and the manual LED flashes.

The  button must be pressed once more to begin the start sequence.

6.3 Remote start panel operation

Ensure 3110 module is in remote.

Press start button to start generator, green lamp will illuminate when generator is running & voltage is within limits.

Red lamp or remote module will illuminate to indicate any faults. (Faults will need to be re-set at generator)

Press stop button to stop.

6.4 Starting sequence

If a start request is present, the fuel relay is energised and the engine will be cranked. If the engine fails to fire during this cranking attempt then the starter motor is disengaged for the

crank rest duration after which the next start attempt is made. Should this sequence continue beyond 3 attempts, the start sequence will be terminated and the display shows **Fail to Start**. When the engine fires, the starter motor is disengaged. Speed detection is factory configured to be derived from the main alternator output frequency.

After the starter motor has disengaged, the *Safety On* timer activates (10 Sec), allowing Oil Pressure, High Engine Temperature, Under-speed, Charge Fail and any delayed Auxiliary fault inputs to stabilise without triggering the fault.

6.5 Engine running

Once the engine is running and all starting timers have expired, the animated icon is displayed.

If all start requests are removed, the *stopping sequence* will begin.



6.6 Stopping the engine

In manual mode the set will continue to run until either:

The *stop button*  is pressed – The set will immediately stop

The *auto button*  is pressed. The set will observe all auto mode start requests and stopping timers before beginning the *Auto mode stopping sequence*.

6.7 Automatic operation

Activate auto mode by pressing the  pushbutton. The  icon is displayed to indicate Auto Mode operation if no alarms are present.

Auto mode will allow the generator to operate fully automatically, starting and stopping as required with no user intervention.

6.8 Waiting in auto mode

If a starting request is made, the starting sequence will begin.

Starting requests can be from the following sources:

Activation of an auxiliary input that has been configured to *remote start*.

6.9 Viewing the instruments

It is possible to scroll to display the different pages of information by repeatedly operating the scroll button .

Once selected the page will remain on the LCD display until the user selects a different page or after an extended period of inactivity, the module will revert to the status display.

When scrolling manually, the display will automatically return to the Status page if no buttons are pressed for the duration of the configurable *LCD Page Timer*.

If an alarm becomes active while viewing the status page, the display shows the Alarms page to draw the operator's attention to the alarm condition.

Page order:-

Engine speed

Generator volts









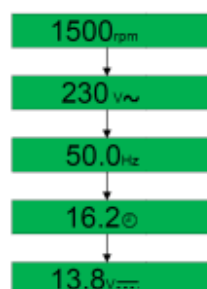







Generator frequency

Engine run time

Battery volts

6.10 Fault icons



	AUXILIARY INPUTS	Auxiliary inputs can be user configured and will display the message as written by the user.
	FAIL TO START	The engine has not fired after the pre-set number of start attempts.
	FAIL TO STOP	The module has detected a condition that indicates that the engine is running when it has been instructed to stop. <div style="border: 1px solid black; padding: 5px;">NOTE:- 'Fail to Stop' could indicate a faulty oil pressure sensor - If engine is at rest check oil sensor wiring and configuration.</div>
	LOW OIL PRESSURE	The module detects that the engine oil pressure has fallen below the low oil pressure pre-alarm setting level after the <i>Safety On</i> timer has expired.
	ENGINE HIGH TEMPERATURE	The module detects that the engine temperature has exceeded the high engine temperature pre-alarm setting level after the <i>Safety On</i> timer has expired.
	UNDERSPEED	The engine speed has fallen below the underspeed pre alarm setting.
	OVERSPEED	The engine speed has risen above the overspeed pre alarm setting.
	CHARGE FAILURE	The auxiliary charge alternator voltage is low as measured from the W/L terminal.
	LOW FUEL LEVEL	The level detected by the fuel level sensor is below the low fuel level setting. (Optional)
	BATTERY UNDER VOLTAGE / BATTERY OVER VOLTAGE	The DC supply has fallen below or risen above the low/high volts setting level.
	GENERATOR UNDER VOLTAGE	The generator output voltage has fallen below the pre-set pre-alarm setting after the <i>Safety On</i> timer has expired.
	GENERATOR OVER VOLTAGE	The generator output voltage has risen above the pre-set pre-alarm setting.
	GENERATOR UNDER FREQUENCY	The generator output frequency has fallen below the pre-set pre-alarm setting after the <i>Safety On</i> timer has expired.
	GENERATOR OVER FREQUENCY	The generator output frequency has risen above the pre-set pre-alarm setting.
	EMERGENCY STOP	The emergency stop button has been depressed. This is a failsafe (normally closed to battery positive) input and will immediately stop the set should the signal be removed. Removal of the battery positive supply from the emergency stop input will also remove DC supply from the Fuel and Start outputs of the controller. <div style="border: 1px solid black; padding: 5px;">NOTE:- The Emergency Stop Positive signal must be present otherwise the unit will shutdown.</div>
	INTERNAL MEMORY ERROR	The configuration file is corrupted. Contact your supplier for assistance.

6.11 Fault finding 3110

Unit is inoperative Read/Write configuration does not operate	Check the battery and wiring to the unit. Check the DC supply. Check the DC fuse.
Unit shuts down	Check DC supply voltage is not above 16 Volts or below 9 Volts Check the operating temperature is not above 70°C. Check the DC fuse.
Unit locks out on Emergency Stop	Check emergency stop switch is functioning correctly. Check wiring is not open circuit.
Low oil Pressure fault operates after engine has fired	Check engine oil pressure. Check oil pressure switch/sensor and wiring, switch is Normally closed and opens with pressure.
High engine	Check engine temperature.

Temperature fault operates after engine has fired.	Check switch/sensor and wiring. Check switch polarity is correct Normally closed.
Shutdown fault operates	Check relevant switch and wiring of fault indicated on LCD display. Check configuration of input.
Warning fault operates	Check relevant switch and wiring of fault indicated on LCD display. Check configuration of input.
Fail to Start is activated after pre-set number of attempts to start	Check wiring of fuel solenoid. Check fuel lift pump operational & fuel supply to engine. Check battery supply. Check battery supply is present on the Fuel output of the module.
Continuous starting of generator when in AUTO	Check that there is no signal present on the "Remote Start" input. Check configured polarity is correct.
Generator fails to start on receipt of Remote Start signal.	Check Start Delay timer has timed out. (Not configured on standard builds) Check signal is on "Remote Start" input. Confirm correct configuration of input is configured to be used as "Remote Start". Check that the oil pressure switch or sensor is indicating low oil pressure to the controller. The set will not start if oil pressure is not low.
Starter motor inoperative	Check wiring to starter solenoid. Check battery supply. Check battery supply is present on the Starter output of module. Ensure oil pressure switch or sensor is indicating the "low oil pressure" state to the 3110 controller.
Engine runs but generator will not take load	Check MCB is switched on.
Fail to stop alarm when engine is at rest	Check low oil pressure switch is operating correctly. Check engine is operating correctly.
Module appears to 'revert' to an earlier configuration	When editing a configuration using the PC software it is vital that the configuration is first 'read' from the controller before editing it. This edited configuration must then be "written" back to the controller for the changes to take effect. When editing a configuration using the Front Panel Editor, be sure to press the  Save button to save the change before moving to another item or exiting the Front Panel Editor.
Inaccurate generator measurements on controller display	The 3110 controller is true RMS measuring so gives more accurate display when compared with an 'average' meter such as an analogue panel meter or some lower specified digital multimeters. Accuracy of the controller is better than 1% of full scale. Ie Gen volts full scale is 333V ph-n so accuracy is $\pm 3.33V$ (1% of 333V).

▲ NOTE:- The above fault finding is provided as a guide check-list only. For further information <http://www.deepseapl.com/>

6.12 Fault finding general

High engine temperature	Check for loose wires on the temperature switch & DC loom connector block. Check the continuity of the earth wire. (Refer to wiring diagram) Check operation of the Temperature switch. Check that the generator air inlets and outlets are not obstructed.
Low oil pressure	Check Oil level and fill to correct level if necessary Check for loose wires on the Oil switch & DC loom connector block. Check the continuity of the earth wire. (Refer to wiring diagram) Check operation of Oil switch.

HZ / Frequency shutdown & Voltage shutdown	Check reset button not tripped and reset if required. Check AC Input at module 230V Check engine speed is set to 52.5Hz at no load. Adjust if required (Speed should be set when engine is cold) Check AC supply from alternator. (If no output refer to alternator handbook) Check fuse on AVR. Check engine has been regularly serviced.
No power to control module	Check reset button not tripped and reset if required. Check 12V DC supply to module. If supply present but not operational try new unit. Check battery voltage. Check battery isolator switch is on. Check for loose wires on battery isolator. Check for loose wires on the DC connector plug and socket. Check continuity on +VE and -VE wires to battery.
Battery not charging	Check for loose wires on charge alternator. Check for loose wires on the DC connector plug and socket. Check continuity of all wires from charge alternator. (Refer to wiring diagram) Check AC voltage at Green / White wires from engine to regulator 35V. Check voltage at the battery while generator is running, voltage should be 13.4V - 14.4V.
Engine not starting	Check battery voltage is above 12.5V. Check Oil level and fill to correct level if necessary. Check fuel level. Check operation of fuel lift pump. Check fuel is reaching the injectors. When running correctly fuel should be running freely from the injector return pipe. If no fuel running from return check the fuel filters & check condition of fuel. Check no air in system. Keep fuel pump running using prime button for 20-30 seconds.
Starter Motor not operating	Check Emergency stop. Check the fuses. Check battery voltage is above 12.5V. Check for loose wires on the solenoid, relays, fuses, module terminals, plug and socket. Check +VE supply from battery to starter motor via isolator switch. Check -VE supply. Check start terminal on Starter motor & trace back to battery via relay. Check start terminal on Starter motor & trace back to module via relay, plug & socket.
Fuel solenoid not operating	Does the Fuel solenoid energise when the starter motor turns over. Check Emergency stop. Check the fuses. Check battery voltage is above 12.5V. Check for loose wires on the solenoid, relays, fuses, module terminals, plug and socket. Check -VE supply. Check +VE on Fuel solenoid & trace back to battery via relay. Check +VE on Fuel solenoid & trace back to module via relay, plug & socket.

7 Service and maintenance

IMPORTANT WARNING:

After any service on the generator, ensure that all piping and electrical cables are correctly routed and secured away from hot parts. Failure to observe this warning may result in damage to the piping and cables which could result in a fire.

Do not service or work on generator whilst the engine is running, also ensure battery is disconnected.

7.1 Removal instructions for SSD6000W2 Generator

- 1) Remove 2 x M8 Socket Capscrews(6mm Allen key) fixing manifold pipe to silencer.



- 2) Remove 3 x M8 Bolts fixing generator mounting frame to base.

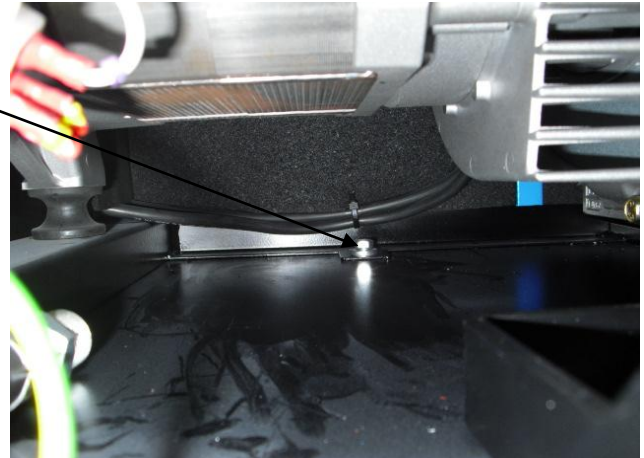
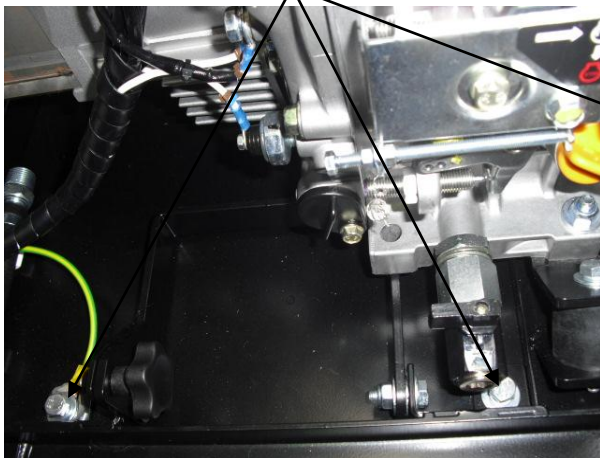

- 3) Remove air filter pipe.
- 4) Disconnect Earth lead & Plugs / Sockets for AC & DC supply.



- 5) Pull Generator out far enough to allow support leg to be lowered.

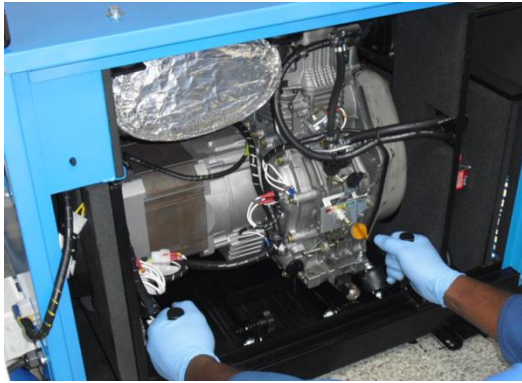

- 6) Refitting is a reversal of removal, please ensure earth leads are connected and exhaust gasket is in place.

7.2 Engine service

Service the engine strictly in accordance with the instructions given in the relevant operator manual / handbook. An approved specialist must carry out any maintenance. Any spare parts required should be of genuine manufacturer's origin. Note: failure to adhere to manufacturer's recommended service schedules may invalidate the warranty. Please consult engine operator's manual for full service intervals.

7.3 Alternator service

Brushless alternators employed on Stephill Generators are maintenance free. Service must be carried out by competent qualified personnel strictly in accordance with the instructions given in the handbook. Any spare parts required should be of genuine manufacturer's origin.

8 MECCALTE Alternator spares

Part No	Description
018 0063	Diode
037-0019	35µf Capacitor

9 Yanmar consumable spares

Part No	Description
029-0007	Air filter
022-1013	Fuel filter (In line)
029-0032	Oil filter

10 Spares SSD6000W2

Part No	Description	Qty
018-0013	Meccalte Alternator S20W - 95	1
029-0022	Engine L100	1
018-0054	50mm Grommet	1
020-0128	Temp switch bracket	1
022-0613	Fan adaptor	1
022-0614	Fan cowl	1
022-1004	Temperature switch	1
022-1035	Fan	1
022-1036	Fan adaptor	1
022-1037	Facet fuel lift pump	1
026-1143	SSD6000W2 Tail pipe	1
026-1144	SSD6000W2 Silencer	1
026-1145	SSD6000W2 Manifold pipe	1
026-2013	Wing housing (Door lock)	2
026-2025	Door lock cam	2
026-2016	Oil drain kit	1
026-2017	½" BSP Dowty washer	1
026-2019	46mm Parallel pipe clamp	1
026-2020	SSD6000W2 Exhaust gasket (Not for engine manifold)	1

Part No	Description	Qty
026-2022	Lobe Knob M8	1
027-0053	M8 Alternator mount	2
027-0054	M8 Engine mount	2
027-0055	M8 Generator mount	4
027-0056	M8 Mount Tempsyl	5
036-0009	MCB 20Amp 2pole	1
036-0028	RCD 40Amp 2 pole	1
036-0050	Re-set button 20Amp	1
044-0011	32A Panel mounted angled socket	1
045-0019	Emergency stop	1
045-0061	Deep Sea 3110 Module	1
045-0062	Deep Sea 3110 Gasket	1
047-0001	25mm Battery cable	5M
048-0004	Fuel filter (In line)	1
056-0002	Relay-4pin 12V DC	2

11 WARRANTY

This generator supplied by STEPHILL GENERATORS LTD carries a warranty of 12 months from date of despatch or 2000 Hours.

During the warranty period, should the plant fail due to faulty design, materials or workmanship by STEPHILL or its sub-contractors, we undertake to rectify the fault.

STEPHILL will accept no responsibility whatsoever for equipment that has failed due to;

- Operation with incorrect fuel, lubricating oil.
- Improper repair or use of parts not supplied by STEPHILL.
- Lack of, or incorrect maintenance.
- Fair wear and tear, misuse, negligence, accidental damage, improper storage, incorrect starting / warm-up / run-in or shutdown.

No warranty claim will be considered by STEPHILL unless any defective parts are available for inspection by us, or our nominees, to determine the reason or cause of failure, and STEPHILL is given the option of repair or replacement.

STEPHILL are not responsible for incidental or consequential damages, downtime, or other costs due to warrantable failure, and unauthorised alterations made to any product supplied by STEPHILL.

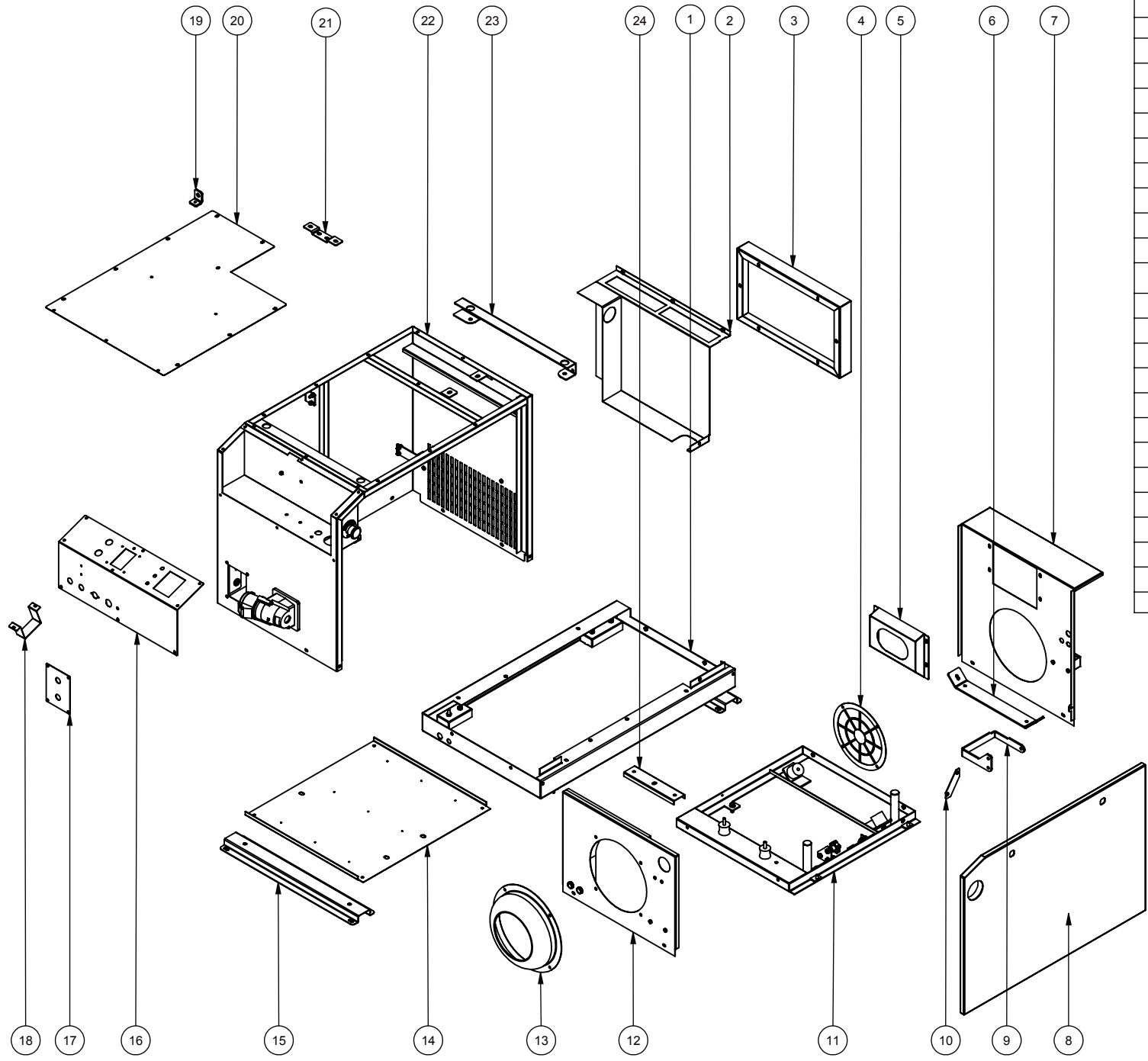

	Part No	Description	Qty
1	026-1180	SSD6000W Mark 2 Base	1
2	026-1147	SSD6000W Air inlet baffle	1
3	026-1140	SSD6000W Air inlet duct	1
4	026-1164	SSD6000W L100 Fan guard	1
5	026-1165	SSD6000W L100 Air filter cover	1
6	22-538	SE6000D Engine mounting bracket	1
7	026-1119	SSD6000W Engine divider plate	1
8	026-1178	SSD6000W Mark 2 door	1
9	026-1130	SSD6000W Generator mounting frame leg	1
10	026-1175	SSD6000W Engine divider brace	1
11	026-1138	SSD6000W Generator mounting frame	1
12	026-1186	SSD6000W Meccalte alternator divider plate	1
13	22-614	SE6000D Fan cowl	1
14	026-1118	SSD6000W Base plate	1
15	026-1111	SSD6000W Skid	2
16	026-1177	SSD6000W Mark 2 control panel	1
17	026-1149	SSD6000W Battery gland plate	1
18	026-1182	SSD6000W2 MCB Bracket	1
19	026-1146	SSD6000W Lifting eye	2
20	026-1184	SSD6000W Mark 3 Roof	1
21	026-1183	SSD6000W Mark 3 Tail pipe bracket	1
22	026-1185	SSD6000W Mark 3 Canopy side	1
23	026-1188	SSD6000W Mark 3 Silencer bracket	1
24	026-1187	SSD6000W Meccalte alternator channel	1



STEPHILLS GENERATORS
 Phone : +44 (0)1933 677911
 Fax : +44 (0)1933 677916

Drawing Number
 026-1190
 Drawn
 R Golding

Description
 SSD6000W2 Mark 3 Exploded view

Issue	Date	Revision
A	16/11/11	New drawing

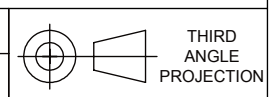
Colour
 As per purchase spec
 Material
 Mild steel



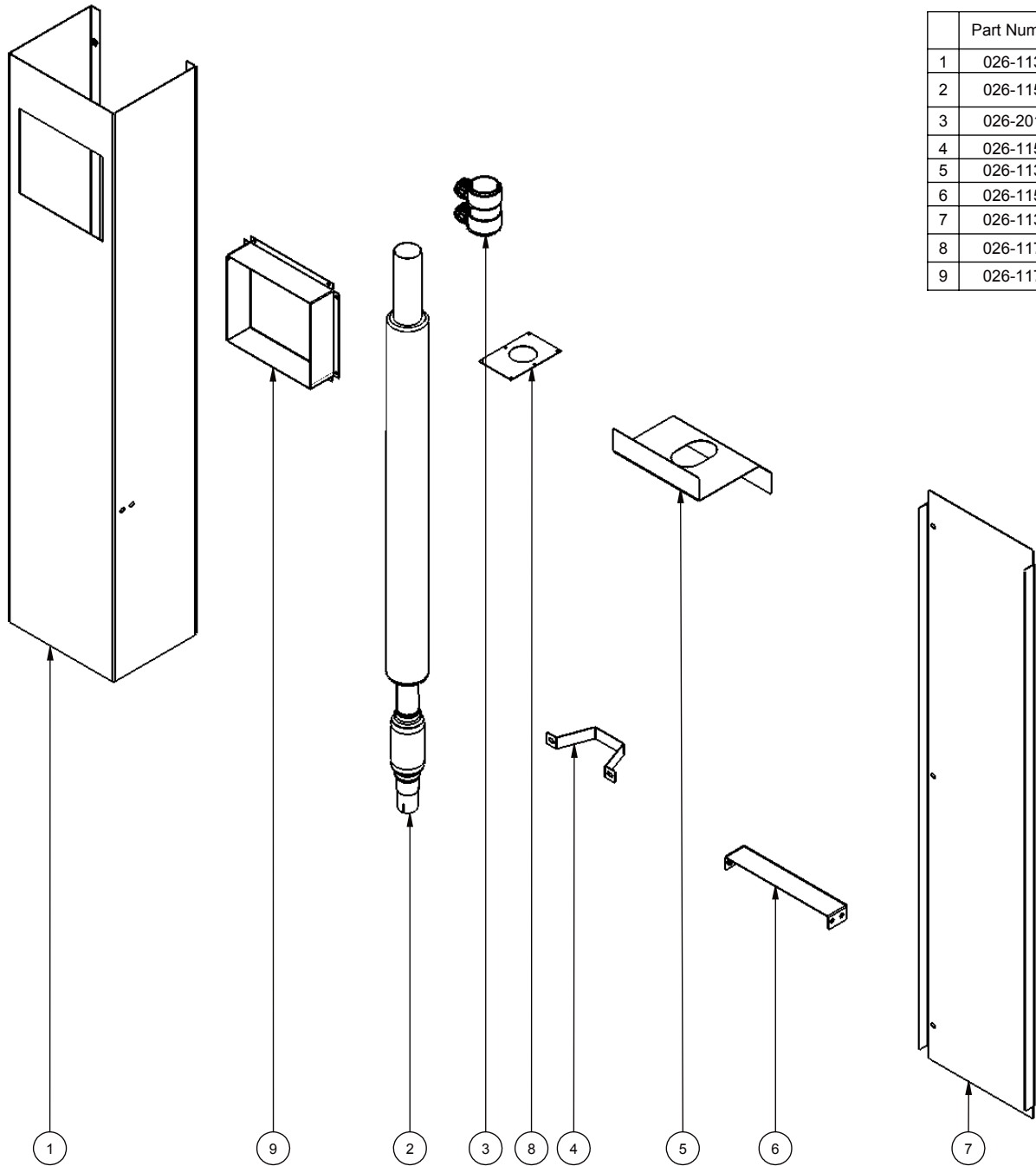

Part Number	Description
1	026-1133 SSD6000W Container air outlet duct
2	026-1151 SSD6000W Secondary silencer
3	026-2015 54 mm Parallel pipe clamp
4	026-1154 SSD6000W Container silencer U bracket
5	026-1132 SSD6000W Container silencer deflector plate
6	026-1153 SSD6000W Container silencer bracket
7	026-1134 SSD6000W Container air outlet duct plate
8	026-1173 SSD6000W Container silencer blank plate
9	026-1174 SSD6000W Air outlet duct spacer (Optional)

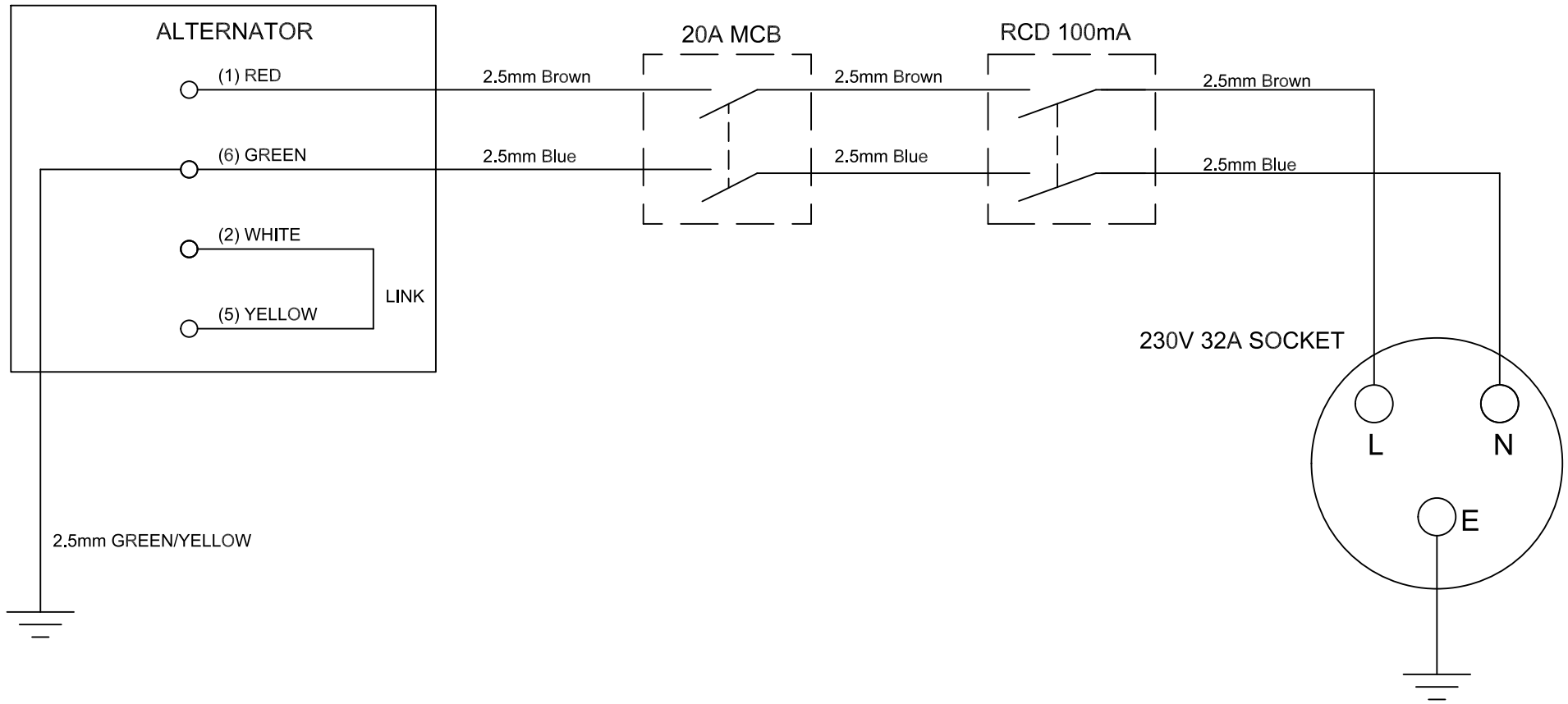

STEPHILL GENERATORS

Phone 01933 677911
Fax 01933 677916

Drawing Number
SW12059

Drawn
R GOLDING

Description
SSD6000W2 230V 32A Socket
MCB RCD

Last Number Used
6

Issue	Date	Revision
A	28/07/10	New drawing
B	21/09/11	RCD description changed.
C	16/11/11	Wiring changed for Meccalte alternator.

