



AUTOMATIC TRANSFER SWITCH PANEL (ATS)

1 Phase 230v

OPERATION AND MAINTENANCE

**Stephill Generators Ltd
Wallis close
Park Farm South
Wellingborough
Northants
NN8 6AG**

**Tel : +44 (0)1933 677911
Fax: +44 (0)1933 677916**

**E-mail : info@stephill-generators.co.uk
Web : www.stephill-generators.co.uk**

CONTENTS		PAGE
1.0	Safety	1
2.0	Installation	1
2.1	Electrical installation	1
3.0	ATS Panel Equipment	1
3.1	ATS control – ENKO ATS 1.1	1
3.2	Monitoring and Indicators	1-2
3.3	Modes of operation	2
3.4	ATS 1.1 Programming	2-3
3.5	ATS 1.1 Parameters	3
3.6	Battery charger on/off switch & lamp	4
3.7	Change over contactors	4
3.8	Control fuses	4
3.9	AC Ammeter	4
3.10	Emergency stop	4
4.0	Check list for automatic operation	4
5.0	System test	4
6.0	Warranty	4
	1 Phase Auto Transfer Switch wiring diagram	5
	ATS Generator Mains Interconnection Wiring	6

1 Safety

Warning

ATS Panel should only be installed, maintained or serviced by a qualified electrician.

The generator set may start without warning whilst in AUTO mode.

Before undertaking any service or maintenance work, ensure the mains and generator supply are isolated and generator is switched to off.

The generator is supplied with the battery disconnected/isolated for safety reasons and should not be re-connected until all connections have been made.

Because of the nature of the equipment and the permanent mains connection, the terminals within the generator may be LIVE even if the generator itself is not running.

2 Installation

Make sure that the Generator is at least one metre away from any building during operation.

Operate in a well ventilated unconfined area, so that fumes can be properly dispersed.

Silencer outlet should be facing an open area to prevent fumes being recirculated.

Consideration will also need to be made for refuelling and maintenance.

If installing in a confined area please consult manufacturer.

2.1 Electrical installation

AC Wiring

Please ensure the correct cross sectional area of cable between the Alternator/Panel and Distribution board used is adequate to carry the full rated continuous output of the generator, allowing for derating in high ambient temperatures. Please consult IEE regulations as per the correct sizing of cable and other issues regarding wiring. Flexible cable is recommended for alternator connections allowing for a generous loop before the cable enters the alternator terminal box because of the vibration caused by the set starting. If this is not possible a terminal box can be fitted nearby and flex fitted between this and the generator terminal box. These precautions will not be needed when fixing to a control box which is not attached to the Alternator. Please refer to Wiring diagram.

DC Wiring

For the DC wiring we recommend 1.5mm if the generator is more than 10Meters away please consult manufacturer for cable sizing. Please refer to Wiring diagram.

3 ATS Panel Equipment

3.1 ATS control – ENKO ATS 1.1

ATS1.1 automatic transfer unit is a microprocessor based digital unit monitoring the 3 phases of the mains and controls the changeover of mains and generator contactors if a mains failure on any phase is detected. The module is able to display all the parameters which are essential for the basic gen-set transfer control. The module has 3 operation modes. Test on load, test off load and Auto operation modes can be chosen via the push-buttons mounted on the front panel.

3.2 Monitoring and Indicators:

◀ = MENU

By pressing the menu button the voltage and frequency measurements can be displayed on the unit.

- L1-N Mains Voltage
- L2-N Mains Voltage
- L3-N Mains Voltage

- Mains Frequency
- L13 Mains Voltage R-T
- L23 Mains Voltage S-T
- L12 Mains Voltage R-S
- L1-N Generator Voltage
- Generator Frequency

Display Leds:

- G: Indicates the displayed value is a generator voltage or frequency
- M: Indicates the displayed value is a mains voltage or frequency

3.3 Modes of operation

OFF Mode:

The module is placed into **OFF** mode by pressing **MENU & TEST OFF LOAD** buttons together. **OFF** mode is used for stopping the engine. If **OFF** button (**MENU & TEST OFF LOAD**) is pressed while the module is in **AUTO**, **TEST ON** or **TEST OFF** modes, the module will de-energise the generator contactor output relay if they are energised, and if the engine is running on load the module will allow the alternator to run off load to cool it adequately. When the cooling time is expired, the module will de-energise the start output and the engine is brought to rest.

AUTO Mode:

The module is placed into auto mode by pressing auto button. If a mains failure on any phase is detected after the mains failure delay timer expires, the load is switched off from the mains and the ATS unit will automatically issue a start command to the genset controller by using the parameters settings. When the generator operates within the limits the load is transferred to the generator by the ATS module. When the mains supply has been restored after the mains transition delay timer expires, the ATS module will transfer the load back from the generator to the mains supply and remove the start command from the genset controller after the cooling time. In case of a failure while operating, the unit will stop the generator automatically. A clear mimic diagram and LEDs provide information about the load status and voltages.

TEST ON LOAD :

This is used to manually start the engine on load even when the mains voltage is within the limits.

TEST OFF LOAD :

This is used to manually start the engine off load even when the mains voltage is within the limits. The load is supplied by the mains but if the mains supply fails, then the load is transferred to the generator automatically.

3.4 ATS 1.1 Programming

Press "**MENU & TEST OFF LOAD**" buttons simultaneously (display = - - -)

Press "**MENU**" (display = 000)

Press "**TEST OFF LOAD**" until number 001 appears.

Press "**MENU**" (display = P00)

Press "**TEST OFF LOAD**" to change program number.

Press "**A**" to change program number digit.

After selecting the program number pressing menu button again will place the unit into the parameter mode. The parameter can then be adjusted.

Press "**TEST OFF LOAD**" to increase number.

Press "**TEST ON LOAD**" to decrease number.

Press "**A**" to change program number digit.

Press "**MENU**" to confirm new value.

The configured value is written to the memory with display flashing 3 times.

If the adjusted password is faulty, faulty message (Err) is displayed.

If the adjusted parameter is out of limits, faulty message (Err) is displayed for 3 seconds and the parameter will have to be adjusted again.

To leave from the programming menu, off button (“**MENU & TEST OFF LOAD**” button) has to be pressed.

Press “**A**” to place unit back into auto.

3.5 ATS 1.1 Parameters

Parameter	Configurable parameter:	Setting
P0	Customer Code:	
P1	Generator voltage lower limit:	207
P2	Generator voltage upper limit:	253
P3	Generator frequency lower limit:	45
P4	Generator frequency upper limit:	55
P5	Mains voltage lower limit:	207
P6	Mains voltage upper limit:	260
P7	Mains frequency lower limit:	45
P8	Mains frequency upper limit:	55
P9	Voltage Hysterisis:	10
P10	Remote Start output delay:	3
P11	Generator fault control delay:	5
P12	Mains transition delay:	30
P13	Mains fault control delay:	3
P14	Mains contactor delay:	1
P15	Generator contactor delay:	5
P16	Engine cooling duration:	180
P17	Mains Frequency Enable:	1
P18	Generator Frequency Enable:	1
P19	Remote Start Output Selection:	0
P20	Aux Input 1:	10
P21	Input Configuration:	0
P22	Aux Input 2:	0
P23	Input Configuration:	
P24	Aux Input 3:	0
P25	Input Configuration:	
P26	Aux Output 1:	0
P27	Output Configuration:	
P28	Aux Output 2:	0
P29	Output Configuration:	
P30	Fault control delay:	4
P31	Default parameters:	0
P32	Password:	1
P33	Power On Operating Mode:	1
P34	Mains control in off mode:	1
P35	Calibrations L1	145
P36	Calibrations L2	145
P37	Calibrations L3	145
P38	Calibrations GEN	145

3.6 Battery charger On/Off switch & lamp

To isolate the mains operated battery charger which maintains the engine starter battery to a healthy condition. Under normal circumstances this is left in the on position, with lamp illuminated.

3.7 Change over contactors

Pair of suitably rated contactors, one for each supply, electrically and mechanically interlocked to avoid paralleling of supplies.

3.8 Control fuses

Refer to circuit diagram for fuse ratings.

3.9 AC Ammeter

Monitors AC Current on Load.

3.10 Emergency stop

When the Emergency stop is activated, the module will de-energise generator contactor output relay. The module will issue a stop command to stop the generator at the same time.

4 Check list for automatic operation

1. Auto mode selected on ATS 1.1 unit.
2. Generator output MCB in on position.
3. Generator in auto mode.
3. Battery charger switched on.

5 System test

It is recommended that the generator is tested every week and run on load for 30 minutes.

6 Warranty

All equipment supplied by STEPHILL GENERATORS LTD carries a warranty of 12 months from date of despatch.

During the warranty period, should the plant fail due to faulty design, materials or workmanship by STEPHILL or it's sub-contractors, we undertake to rectify the fault by replacement or repair at our option.

STEPHILL will accept no responsibility whatsoever for equipment that has failed due to;

- Improper repair or use of parts not supplied by STEPHILL.
- Lack of, or incorrect maintenance.
- Fair wear and tear, misuse, negligence, accidental damage, improper storage, incorrect starting / warm-up / run-in or shutdown.

No warranty claim will be considered by STEPHILL unless any defective parts are available for inspection by us, or our nominees, to determine the reason or cause of failure, and STEPHILL is given the option of repair or replacement.

STEPHILL are not responsible for incidental or consequential damages, downtime, or other costs due to warrantable failure, and unauthorised alterations made to any product supplied by STEPHILL.

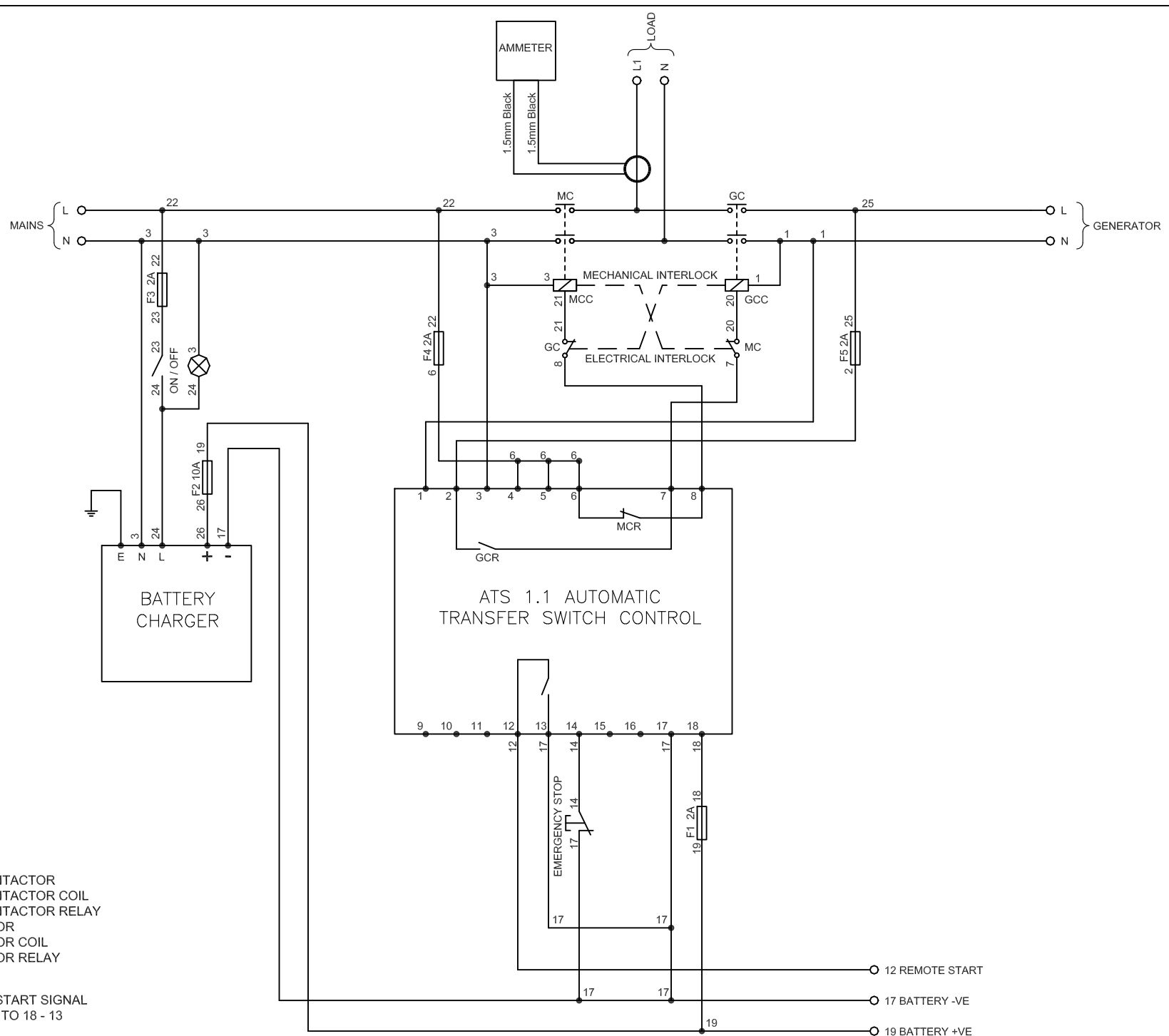

LEGEND

- GC = GENERATOR CONTACTOR
- GCC = GENERATOR CONTACTOR COIL
- GCR = GENERATOR CONTACTOR RELAY
- MC = MAINS CONTACTOR
- MCC = MAINS CONTACTOR COIL
- MCR = MAINS CONTACTOR RELAY

NOTE

FOR POSITIVE REMOTE START
 MOVE LINK FROM 17 - 13 TO 18 - 13



STEPHILL GENERATORS

Phone 01933 677911
 Fax 01933 677916

Drawing Number
 SW180002

Drawn
 R Golding

Description
 1 Phase Auto Transfer Switch
 wiring diagram

Last Number Used
 26

Issue	Date	Revision
A	29/10/07	New drawing
B	15/01/09	Wire number 26 changed.

ATS PANEL

GENERATOR

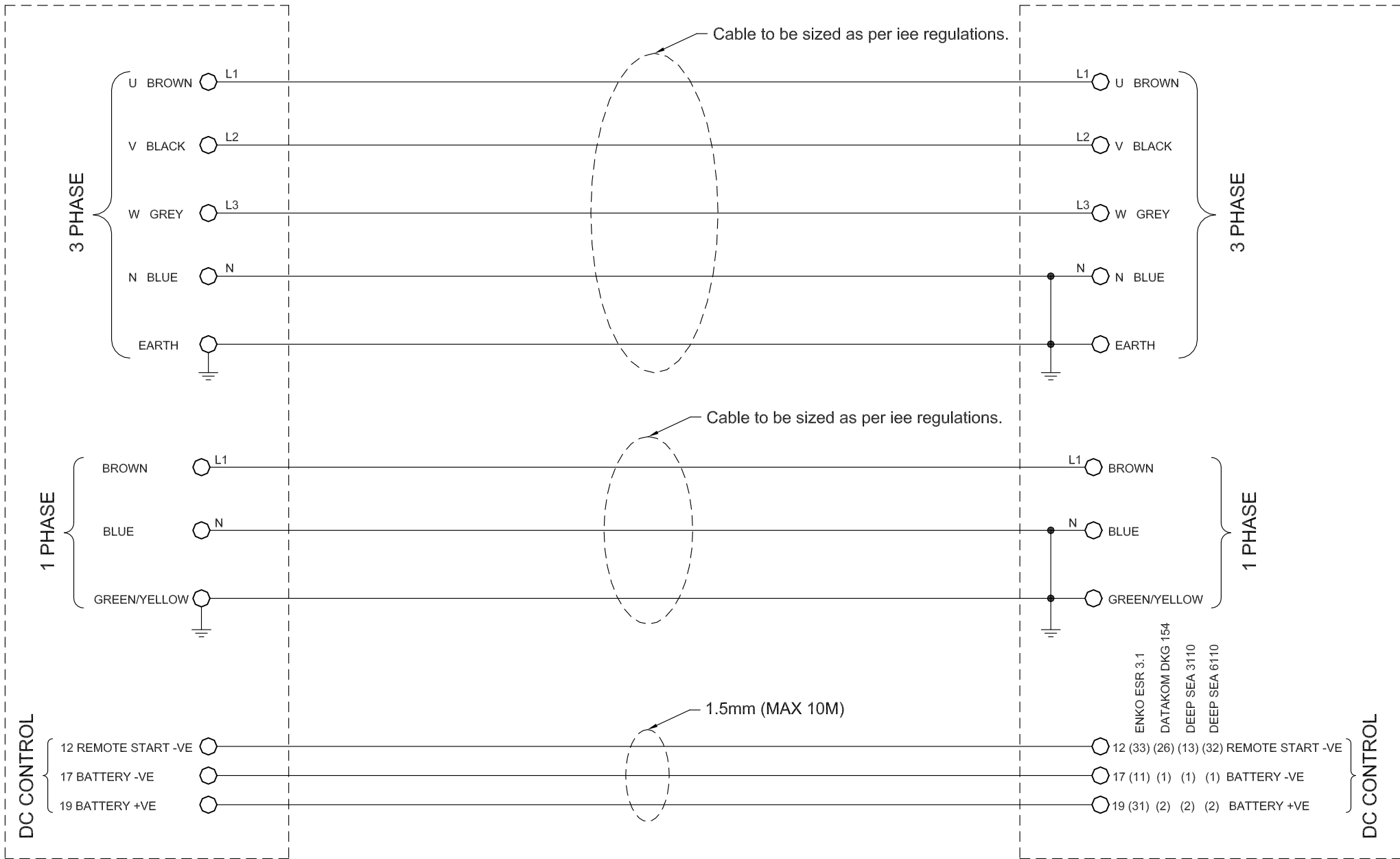

Issue	Date	Revision
D	06/10/10	Wiring added for Deep sea 6110.
C	18/09/09	Wiring added for Deep sea 3110.
B	10/09/08	DC Control wiring changed.

ATS1.1 AUTOMATIC TRAFER SWITCH KONTROL UNIT OPERATORS MANUAL

INTRODUCTION

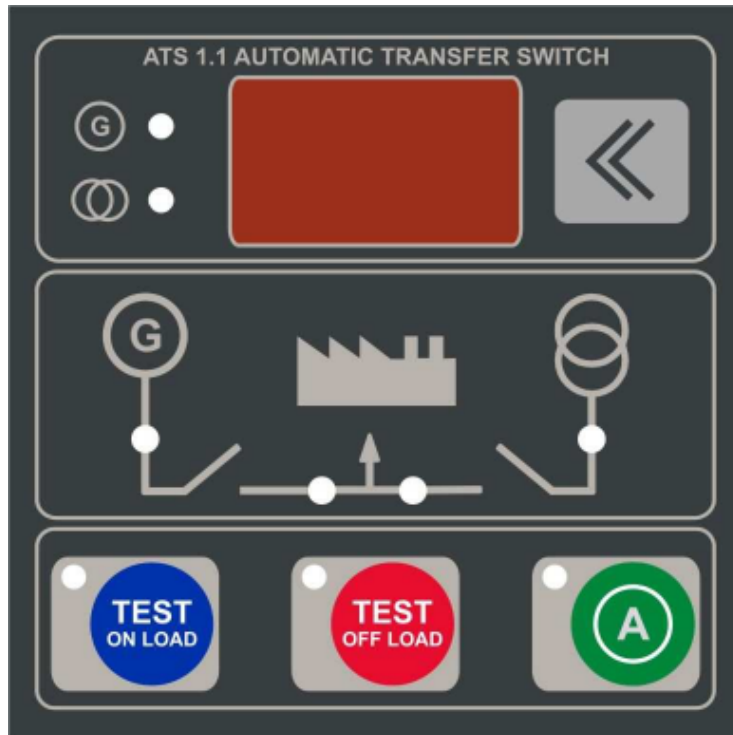

ATS 1.1 automatic transfer unit is a microprocessor based digital unit monitoring the 3 phases of the mains and controls the changeover of mains and generator contactors if a mains failure on any phase is detected. The module offers a very cost effective and space saving solutions as it is able to display all the parameters which are essential for the basic genset transfer control. The module has 3 operation modes. Test on load, test off load and Auto operation modes can be chosen via the push-buttons mounted on the front panel. The 39 parameter settings can also be adjusted from the front panel. So the module can be adapted to all generators without the need of any other unit or module.

Features:

- Micro-processor based design
- Automatic engine starting and stopping commands
- Automatic load transfer
- Configurable via front panel
- Automatic shut down on fault condition
- Test on / off modes
- LED mimic indication
- Operate with cranking dropouts
- 2 configurable auxiliary outputs
- 3 configurable auxiliary inputs

- 3 phase true RMS mains voltage measuring and monitoring
- Mains frequency measuring and monitoring
- Generator phase true RMS voltage measuring and monitoring
- Generator frequency measuring and monitoring
- Digitally adjustable low&high mains and generator voltage limits
- Digitally adjustable generator start command timings
- Digitally adjustable generator overspeed /underspeed limits
- Digitally adjustable mains voltage overspeed/underspeed limits
- Digitally adjustable auxiliary inputs specifications
- Digitally adjustable auxiliary outputs specifications
- Digitally adjustable load transfer timings
- Failure control
- Digitally adjustable warm up/cooling timings
- Digitally adjustable measurement calibrations
- Digital display
- Low cost,small dimensions

Inputs/Outputs:

- 3 phase mains voltage inputs
- Single phase generator voltage input
- 12 / 24 V battery voltage inputs
- Auxiliary1 input
- Auxiliary2 input
- Auxiliary3 input
- Auxiliary1 output
- Auxiliary2 output
- Start command output
- Generator contactor relay output
- Mains contactor relay output

Front View

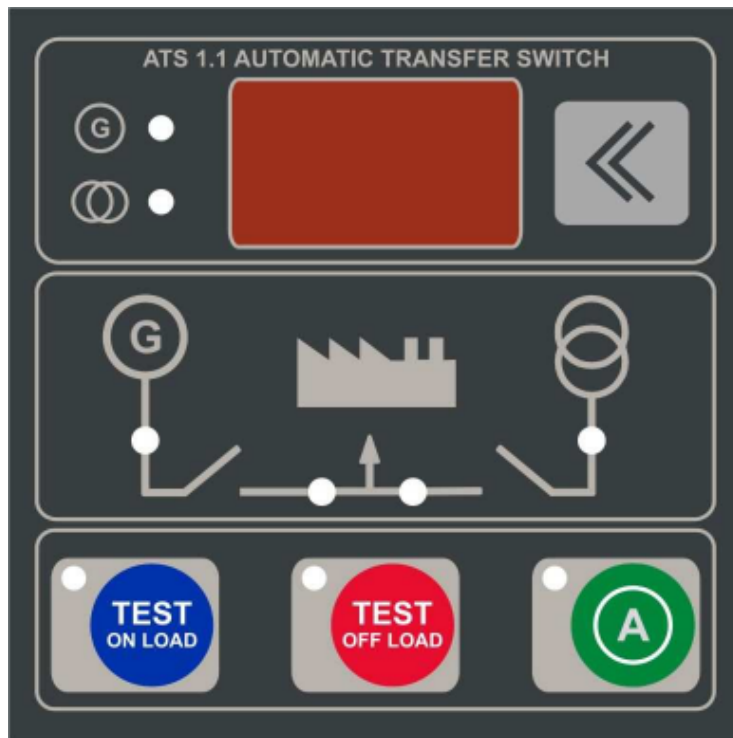

Display: By pressing the menu button in auto ,test on ,test off mode, the voltage and frequency measurements can be displayed on the unit.

- L1-N Mains Voltage
- L2-N Mains Voltage
- L3-N Mains Voltage
- Mains Frequency
- L13 Mains Voltage R-T
- L23 Mains Voltage S-T
- L12 Mains Voltage R-S
- L1-N Generator Voltage
- Generator Frequency

Display Leds:

- G: Indicates the displayed value is a generator voltage or frequency
- M: Indicates the displayed value is a mains voltage or frequency

Automatic Button: Auto button places the unit into automatic mode.

Test On Button: Test on button places the unit into test on mode.

Test Off Button: Test off button places the unit into test off mode.

Off Button (Test Off+Menu button): Off button places the unit into off mode.

Menu Button: By pressing the menu button in auto, test on or test off mode, the voltage and frequency values can be displayed on the unit. If the unit is into off mode, pressing the menu button will place the unit into the password mode. In password mode, the password which will

be adjusted can be chosen with test on(decrease),test off(increase) and auto(changing the digit number) button.After accessing the correct password, by pressing menu button again will place the unit into the menu mode. In menu mode, the menu parameter which will be adjusted can be chosen with the buttons .After selecting the menu parameter, by pressing menu button again will place the unit into the parameter mode. The parameter can be adjusted with the buttons and by pressing menu or off mode , the new parameter is written to the memory .To cancel the menu operations, off button should be pressed.

Mains Contactor Led:Mains contactor LED is activated when the unit energise the mains contactor .

Mains Voltage Led: Mains Voltage LED is activated when the unit detects main voltage in limits.It blinks during the mains voltage safety time after the mains voltage returns.

Generator Contactor Led: Generator contactor LED is activated when the unit energise the generator contactor .

Generator Voltage Led: Generator Voltage LED is activated when the unit detects generator voltage in limits.

Rear View

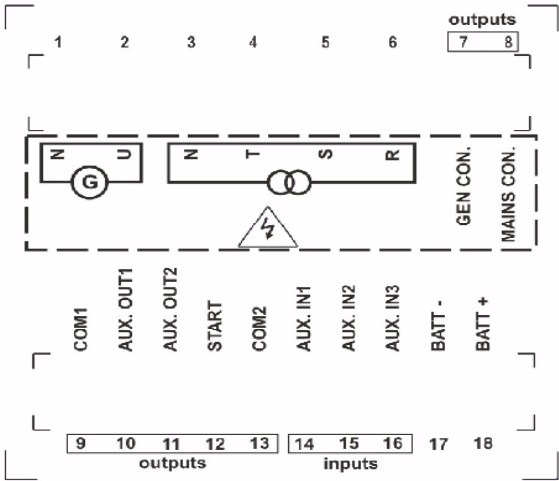

TERMINAL CONNECTIONS

Terminal No:	Description:	Notes:
1	N	Alternator Neutral sensing input
2	U	Alternator R phase voltage sensing input
3	N	Mains Neutral sensing input
4	T	Mains T phase voltage sensing input
5	S	Mains S phase voltage sensing input
6	R	Mains R phase voltage sensing input
7	GEN CON.	Outputs alternator R phase voltage to energise the generator contactor.
8	MAINS CON.	Outputs mains R phase voltage to energise the mains contactor .
9	COM1	Common input for aux output relays

10	AUX.OUT1	Configurable output relay
11	AUX.OUT2	Configurable output relay
12	START	Start command output relay
13	COM2	Common input for start output relay
14	AUX.IN1	Configurable input(negative closing switch input)
15	AUX.IN2	Configurable input(negative closing switch input)
16	AUX.IN3	Configurable input(negative closing switch input)
17	BAT(-)	DC - supply input
18	BAT(+)	DC + supply input

OPERATION MODES

OFF Mode:

The module is placed into off mode by pressing MENU + TEST OFF buttons together. Off mode is used for stopping the engine. If off button (menu+test off buttons) is pressed while the module is in auto, test on or test off modes, the module will de-energise generator contactor output relay if they are energised and if the engine is running on load, the module will allow the alternator to run off load to cool it adequately. When the cooling time is expired, the module will de-energise the start output and the engine is brought to rest.

While the module is in off mode, by pressing the menu button, 39 parameters can be adjusted.

AUTO Mode:

The module is placed into auto mode by pressing auto button. If a mains failure on any phase is detected after the mains failure delay timer expires, the load is switched off from the mains and the ATS unit automatically will issue a start command to the genset controller by using the parameters settings which are adjusted before. When the generator operates within the limits adjusted before, the load is transferred to the generator by the ATS module. When the mains supply has been restored after the mains transition delay timer expires, the ATS module will transfer the load back from the generator to the mains supply and remove start command from the genset controller after cooling time. In case of a failure while operating, the unit will stop the generator automatically. A clear mimic diagram and LEDs provide information about the load status and voltages.

TEST ON Mode :

This is used to manually start the engine on load even the mains voltage is within the limits.

TEST OFF Mode :

This is used to manually start the engine off load even the mains voltage is within the limits. The load is supplied by the mains but if the mains supply fails, then the load is transferred to the generator automatically.

INPUTS/OUTPUTS

DC Supply Input:Battery + DC supply is connected to BATT+ terminal.Battery – DC supply is connected to BATT- terminal.The modul is protected to reverse connection.12/24V battery can be connected by using the same terminals.

Alternator Input:Alternator single phase and neutral outputs are connected alternator inputs of the modul.Alternator voltage and frequency are monitored from these inputs.

Mains Input:Mains 3 phase and neutral supply voltage is connected mains inputs of the modul.Mains voltage and frequency are monitored from these inputs.If only one phase of the mains voltage is required to be monitored, other mains voltage inputs of the modul have to be short circuited with the connected phase voltage.

Auxiliary Input 1:Auxiliary input can be configured as Normally Open input and Normally Close input by adjusting P21 number of the parameter.And the function can be configured as unused,remote start on load, remote start off load, mains simulate ,mains disable, auto start disable,mains contactor disable, generator contactor disable,C type failure input, D type failure input, E type failure input , F type failure input by adjusting the P20 parameter number.If this input will not be used, it has to be configured as NO(P21) and unused(P20) and leaved empty.It is a negative closing switch.

Auxiliary Input 2:Auxiliary input can be configured as Normally Open input and Normally Close input by adjusting P23 number of the parameter.And the function can be configured as unused,remote start on load, remote start off load, mains simulate ,mains disable, auto start disable,mains contactor disable, generator contactor disable,C type failure input, D type failure input, E type failure input , F type failure input by adjusting the P22 parameter number.If this input will not be used, it has to be configured as NO(P23) and unused(P22) and leaved empty. It is a negative closing switch.

Auxiliary Input 3:Auxiliary input can be configured as Normally Open input and Normally Close input by adjusting P25 number of the parameter.And the function can be configured as unused,remote start on load, remote start off load, mains simulate ,mains disable, auto start disable,mains contactor disable, generator contactor disable,C type failure input, D type failure input, E type failure input , F type failure input by adjusting the P24 parameter number.If this input will not be used, it has to be configured as NO(P25) and unused(P24) and leaved empty. It is a negative closing switch.

Mains Contactor Relay Output(250VAC 10A):Mains contactor output is used for energising the mains contactor to transfer load to the mains.It outputs R phase of the mains from its normally close terminal.

Generator Contactor Relay Output(250VAC 10A): Generator contactor output is used for energising the generator contactor to transfer load to the generator.It outputs R phase of the generator from its normally open terminal.

Starter Command Relay Output(250VAC 6A): It outputs the signal connected to com2 .It is activated when the modul issues a start command.

Auxiliary Relay Output 1(250VAC 6A): Auxiliary output can be configured as mains failure output, generator failure output, engine running output,generator on load output, mains on load output,auto mode ready output,module is available output, failure output by adjusting the P26 parameter number.By adjusting the P27 parameter number, the auxiliary relay output is configured as normally open output or normally close output. It outputs the signal connected to com1.

Auxiliary Relay Output 2(250VAC 6A): Auxiliary output can be configured as mains failure output, generator failure output, engine running output,generator on load output, mains on load output,auto mode ready output,module is available output, failure output by adjusting the P28 parameter number.By adjusting the P29 parameter number, the auxiliary relay output is configured as normally open output or normally close output. It outputs the signal connected to com1.

FAILURES

Auxiliary inputs can be configured as C type failure input, D type failure input, E type failure input , F type failure input.Failures are self-acknowledge.When the failure conditions are restored and the failure input is de-activated, failures are reset.If the auxiliary failure is adjusted as one of D,E,F type failures, this input has to be de-activated before the ATS modul issues a start command.

C type failure:When the aux failure input is activated, the modul will de-energise generator contactor output relay.But the engine goes on running.When the failure input is de-activated, the modul will energise the generator contactor again.

D type failure:When the aux failure input is activated, the modul will de-energise generator contactor output relay.But the engine goes on running off load until the cooling time expires.When the cooling time expires, the modul will issue stop command to stop the generator.

E type failure:When the aux failure input is activated, the modul will de-energise generator contactor output relay.The modul will issue stop command to stop the generator at the same time.

F type failure:When the aux failure input is activated, the modul will de-energise generator contactor and mains contactor output relays.The modul will issue stop command to stop the generator at the same time.

PROGRAMING PARAMETERS

Moduls are easily programmed and the parameters are displayed and configured by using push-buttons on the front panel. If the unit is off mode, pressing the menu button will place the unit into the password mode. In password mode, the password which will be adjusted can be chosen with test on(decrease), test off(increase) and auto(changing the digit number) button. After accessing the correct password, by pressing menu button again will place the unit into the menu mode. In menu mode, the menu parameter which will be adjusted can be chosen with the buttons . After selecting the menu parameter, by pressing menu button again will place the unit into the parameter mode. The parameter can be adjusted with the buttons and by pressing menu button, the configured value is written to the memory with display flashing 3 times . With the pressing off button, off mode is returned. To cancel the parameter configuration, off button has to be pressed.

If the adjusted password is faulty, faulty message(Err) is displayed. And one of the buttons have to be pressed to place into a operating modes.

If the adjusted parameter is out of limits, faulty message(Err) is displayed for 3 seconds and the parameter have to be adjusted again. To leave from the programming menu, off button(test off+menu button) has to be pressed.

Parameter Number:	Configurable parameter:	Standard Value:	Minimum Value:	Maximum Value:
P0	Customer Code:		0	999
P1	Generator voltage lower limit:	180	50	600
P2	Generator voltage upper limit:	250	50	600
P3	Generator frequency lower limit:	45	10	99
P4	Generator frequency upper limit:	55	10	99
P5	Mains voltage lower limit:	170	50	600
P6	Mains voltage upper limit:	265	50	600
P7	Mains frequency lower limit:	45	10	99
P8	Mains frequency upper limit:	55	10	99
P9	Voltage Histerisis:	10	1	50
P10	Remote Start output delay:	3	0	300
P11	Generator fault control delay:	5	3	300
P12	Mains transition delay:	60	10	300
P13	Mains fault control delay:	3	1	300
P14	Mains contactor delay:	1	0	300
P15	Generator contactor delay:	9	0	300
P16	Engine cooling duration:	60	0	900
P17	Mains Frequency Enable:	1	0	1
P18	Generator Frequency Enable:	1	0	1
P19	Remote Start Output Selection:	0	0	1
P20	Aux Input 1:	8	0	11
P21	Input Configuration:	1	0	1
P22	Aux Input 2:	9	0	11
P23	Input Configuration:	1	0	1
P24	Aux Input 3:	10	0	11
P25	Input Configuration:	1	0	1
P26	Aux Output 1:	3	0	8
P27	Output Configuration:	0	0	1
P28	Aux Output 2:	1	0	8
P29	Output Configuration:	0	0	1
P30	Fault control delay:	8	3	300
P31	Default parameters:	0	0	1
P32	Password:	1	0	999

P33	Power On Operating Mode:	1	0	3
P34	Mains control in off mode:	1	0	1
P35	Calibrations L1	145	10	300
P36	Calibrations L2	145	10	300
P37	Calibrations L3	145	10	300
P38	Calibrations GEN	145	10	300

DESCRIPTION OF PARAMETERS

No	Parameter	Description
Parameters		
P00	Costemer Code:	All customers have their own code.This parameter shows this code.It can not be configured.
P01	Generator Voltage Lower Limit:	If the voltage of the generator output falls below generator voltage lower limit a shutdown is initiated. The modul will indicate voltage failure.
P02	Generator Voltage Upper Limit:	If the voltage of the generator output exceeds generator voltage upper limit a shutdown is initiated. The modul will indicate voltage failure
P03	Generator Frequency Lower Limit:	If the frequency of the generator output falls below generator frequency lower limit a shutdown is initiated.
P04	Generator Frequency Upper Limit:	If the frequency of the generator output exceeds generator frequency upper limit a shutdown is initiated.
P05	Mains Voltage Lower Limit:	If the voltage of the mains falls below mains voltage lower limit the modul will indicate mains failure.
P06	Mains Voltage Upper Limit	If the voltage of the mains exceeds mains voltage upper limit the modul will indicate mains failure.
P07	Mains Frequency Lower Limit:	If the frequency of the mains voltage falls below mains frequency lower limit , the modul will indicate mains failure.
P08	Mains Frequency Upper Limit:	If the frequency of the mains voltage exceeds mains frequency upper limit , the modul will indicate mains failure.
P09	Voltage Histerisis:	If the voltage of the mains exceeds mains voltage lower limit + voltage histerisis ,the modul will accept the mains normal.
P10	Remote Start Output Delay:	If there is any failure on any phase of the mains voltage , the modul will issue a start command after this timer expires.
P11	Generator fault control delay:	If the generator voltage or frequency is out of acceptable limits, the modul will wait during the generator fault control delay timer before indicating any alarm condition.This parameter is useful during instant load changing.
P12	Mains transition delay:	When the mains returns within the limits,the module will first initiate mains transition delay timer to ensure that it is safe to stop the generator. If the mains voltage has no failure after this timer expires,the modul will initiate mains contactor delay timer.
P13	Mains fault control delay:	The modul accepts mains failure if the failure is active

		during the mains fault control delay timer. After this timer expires, the modul accepts a mains failure.
P14	Mains contactor delay:	If the mains voltage has no failure after the mains transition delay timer expires, the modul will initiate mains contactor delay timer. When the timer expires, the modul will energise the mains contactor output.
P15	Generator contactor delay:	After the starter motor is detected starting, the generator contactor delay timer is activated. After this timer expires, the modul will energise the generator contactor if there is no failure with the generator signals. This parameter must be adjusted bigger than P30 parameter.
P16	Engine cooling duration:	After the modul de-energise the generator contactor output, the module will then initiate its cooling timer. This allows the engine to run off load to ensure that it has adequately cooled before being brought to a standstill.
P17	Mains Frequency Enable:	0-(No): This parameter is selected if the mains frequency is inactive while the modul decides if there is any mains fault. But the modul goes on indicate the mains frequency. 1-(Yes): This parameter is selected if the mains frequency is active while the modul decides if there is a mains fault.
P18	Generator Frequency Enable:	0-(No): This parameter is selected if the generator frequency is inactive while the modul decides if there is a generator fault. But the modul goes on indicate the generator frequency. 1-(Yes): This parameter is selected if the generator frequency is active while the modul decides if there is a generator fault.
P19	Remote Start Output Selection:	Remote start output function can be configured as one of the following: 0-(NO): Remote Start output relay is energised to issue start command. 1-(NC): Remote Start output relay is de-energised to issue start command.
P20	Auxiliary Input 1:	Auxiliary input function can be configured as one of the following: 0-Unused: This parameter is selected if the aux input function isn't used. 1-Remote Start On Load: When the aux input is activated, the modul issues start command and takes load whether the mains voltage is within limits. This function is enabled in auto mode. 2-Remote Start Off Load: When the aux input is activated, the modul issues start command but doesn't take load until there is a mains failure. This function is enabled in auto mode. 3-Mains Simulate: When the aux input is activated, the mains voltage is accepted normal in spite of a mains failure. This function is enabled in auto mode. 4-Mains Failure: When the aux input is activated, the mains voltage is accepted fault. This function is enabled in auto

		<p>mode.</p> <p>5-Auto Start Disable:When the aux input is activated ,the modul is prevented to issue start command.This function is enabled in auto mode.</p> <p>6-Mains Contactor Disable:When the aux input is activated, the modul is disabled to take load to the mains contactor.This function is enabled in auto mode.</p> <p>7-Generator Contactor Disable:When the aux input is activated, the modul is disabled to take load to the generator contactor.This function is enabled in auto mode.</p> <p>8-C type Failure: When the aux input is activated, the modul accepts the signal as a C type failure.This function is enabled in all modes.</p> <p>9-D type Failure: When the aux input is activated, the modul accepts the signal as a D type failure. This function is enabled in all modes.</p> <p>10-E type Failure: When the aux input is activated, the modul accepts the signal as a E type failure. This function is enabled in all modes.</p> <p>11-F type Failure: When the aux input is activated, the modul accepts the signal as a F type failure. This function is enabled in all modes.</p>
P21	Input Configuration:	<p>Auxiliary input can be configured as one of the following:</p> <p>0-NC(Normally Closed): Auxiliary input is configured to activate by disconnecting the input to the battery negative voltage.</p> <p>1-NO(Normally Open): Auxiliary input is configured to activate by connecting the input to the battery negative voltage.</p>
P22	Auxiliary Input 2:	<p>Auxiliary input function can be configured as one of the following:</p> <p>0-Unused:This parameter is selected if the aux input function isn't used.</p> <p>1-Remote Start On Load: When the aux input is activated, the modul issues start command and takes load whether the mains voltage is within limits.This function is enabled in auto mode.</p> <p>2-Remote Start Off Load: When the aux input is activated, the modul issues start command but doesn't take load until there is a mains failure. This function is enabled in auto mode.</p> <p>3-Mains Simulate:When the aux input is activated ,the mains voltage is accepted normal. This function is enabled in auto mode.</p> <p>4-Mains Failure: When the aux input is activated ,the mains voltage is accepted fault. This function is enabled in auto mode.</p> <p>5- Auto Start Disable:When the aux input is activated ,the modul is prevented to issue start command.This function is enabled in auto mode.</p>

		<p>6-Mains Contactor Disable:When the aux input is activated, the modul is disabled to take load to the mains contactor.This function is enabled in auto mode.</p> <p>7-Generator Contactor Disable:When the aux input is activated, the modul is disabled to take load to the generator contactor.This function is enabled in auto mode.</p> <p>8-C type Failure: When the aux input is activated, the modul accepts the signal as a C type failure.This function is enabled in all modes.</p> <p>9-D type Failure: When the aux input is activated, the modul accepts the signal as a D type failure. This function is enabled in all modes.</p> <p>10-E type Failure: When the aux input is activated, the modul accepts the signal as a E type failure. This function is enabled in all modes.</p> <p>11-F type Failure:When the aux input is activated, the modul accepts the signal as a F type failure. This function is enabled in all modes.</p>
P23	Input Configuration:	<p>Auxiliary input can be configured as one of the following:</p> <p>0-NC(Normally Closed): Auxiliary input is configured to activate by disconnecting the input to the battery negative voltage.</p> <p>1-NO(Normally Open): Auxiliary input is configured to activate by connecting the input to the battery negative voltage.</p>
P24	Auxiliary Input 3:	<p>Auxiliary input function can be configured as one of the following:</p> <p>0-Unused:This parameter is selected if the aux input function isn't used.</p> <p>1-Remote Start On Load: When the aux input is activated, the modul issues start command and takes load whether the mains voltage is within limits.This function is enabled in auto mode.</p> <p>2-Remote Start Off Load: When the aux input is activated, the modul issues start command but doesn't take load until there is a mains failure. This function is enabled in auto mode.</p> <p>3-Mains Simulate:When the aux input is activated ,the mains voltage is accepted normal. This function is enabled in auto mode.</p> <p>4-Mains Failure: When the aux input is activated ,the mains voltage is accepted fault. This function is enabled in auto mode.</p> <p>5- Auto Start Disable:When the aux input is activated ,the modul is prevented to issue start command.This function is enabled in auto mode.</p> <p>6-Mains Contactor Disable:When the aux input is activated, the modul is disabled to take load to the mains contactor.This function is enabled in auto mode.</p> <p>7-Generator Contactor Disable:When the aux input is</p>

		<p>activated, the modul is disabled to take load to the generator contactor.This function is enabled in auto mode.</p> <p>8-C type Failure: When the aux input is activated, the modul accepts the signal as a C type failure.This function is enabled in all modes.</p> <p>9-D type Failure: When the aux input is activated, the modul accepts the signal as a D type failure. This function is enabled in all modes.</p> <p>10-E type Failure: When the aux input is activated, the modul accepts the signal as a E type failure. This function is enabled in all modes.</p> <p>11-F type Failure:When the aux input is activated, the modul accepts the signal as a F type failure. This function is enabled in all modes.</p>
P25	Input Configuration:	<p>Auxiliary input can be configured as one of the following:</p> <p>0-NC(Normally Closed): Auxiliary input is configured to activate by disconnecting the input to the battery negative voltage.</p> <p>1-NO(Normally Open):Auxiliary input is configured to activate by connecting the input to the battery negative voltage.</p>
P26	Auxiliary Output 1:	<p>Auxiliary output function can be configured as one of the following:</p> <p>0-Unused:Auxiliary output is never activated .</p> <p>1-Mains Failure: Auxiliary output is activated when there is a mains failure.</p> <p>2-Generator Failure:Auxiliary output is activated when there is a generator failure.</p> <p>3-Engine Running:Auxiliary output is activated when the modul detects engine running.</p> <p>4-Generator On Load:Auxiliary output is activated when the generator contactor takes load.</p> <p>5-Mains On Load:Auxiliary output is activated when the mains contactor takes load.</p> <p>6-Automatic Mode Ready:Auxiliary output is activated when the modul is in auto mode.</p> <p>7-Module Energised: Auxiliary output is activated when the module is energised.</p> <p>8-Alarm Output:Auxiliary output is activated when there is a failure.</p>
P27	Aux Output Configuration:	<p>Aux output function can be configured as one of the following:</p> <p>0-(NO):Aux output relay is energised when the output is activated.</p> <p>1-(NC): Aux output relay is de-energised when the output is activated.</p>
P28	Auxiliary Output 2:	<p>Auxiliary output function can be configured as one of the following:</p> <p>0-Unused:Auxiliary output is never activated .</p> <p>1-Mains Failure: Auxiliary output is activated when there</p>

		<p>is a mains failure.</p> <p>2-Generator Failure:Auxiliary output is activated when there is a generator failure.</p> <p>3-Engine Running:Auxiliary output is activated when the modul detects engine running.</p> <p>4-Generator On Load:Auxiliary output is activated when the generator contactor takes load.</p> <p>5-Mains On Load:Auxiliary output is activated when the mains contactor takes load.</p> <p>6-Automatic Mode Ready:Auxiliary output is activated when the modul is in auto mode.</p> <p>7-Module Energised: Auxiliary output is activated when the module is energised.</p> <p>8-Alarm Output:Auxiliary output is activated when there is a failure.</p>
P29	Aux Output Configuration:	<p>Aux output function can be configured as one of the following:</p> <p>0-(NO):Aux output relay is energised when the output is activated.</p> <p>1-(NC): Aux output relay is de-energised when the output is activated.</p>
P30	Fault control delay:	<p>If the engine start is successful,the fault control delay timer is activated. This timer allows Under/over speed, Under/over volts to stabilise without triggering the fault. Once the engine is running and the fault control delay timer has expired, full fault protection is made available</p>
P31	Default parameters:	1: All parameters return to the factory defaults.
P32	Password:	Password is used to change the parameters.
P33	Power On Operating Mode:	<p>0-Power on operating mode is selected as OFF mode.</p> <p>1-Power on operating mode is selected as AUTO mode.</p> <p>2-Power on operating mode is selected as TEST ON mode.</p> <p>3-Power on operating mode is selected as TEST OFF mode.</p>
P34	Mains control in off mode:	<p>0-No: The modul control the mains 3 phase voltage. If the mains voltage has no failure, the modul will supply the load with mains voltage in off mode.If there is any failure in any phase of the mains voltage the modul switches off the load from the mains voltage.</p> <p>1-Yes: The modul doesn't control the mains voltage in off mode.It always supplies the load with the R phase of the mains voltage.</p>
P35	Calibrations L1	Mains line R voltage calibration.
P36	Calibrations L2	Mains line S voltage calibration.
P37	Calibrations L3	Mains line T voltage calibration.
P38	Calibrations GEN	Generator R voltage calibration.

SPECIFICATIONS

DC Supply:	9-35VDC 20mA (stop mode) 70mA (auto mode) 110mA(maximum current)
Operating Temperature:	-10°C / +70°C
Relative Humidity:	%10-%95 non-condensing
Relay Outputs:	Start and auxiliary outputs 6A/12-24VDC Generator and mains contactor outputs 10A / 250VAC
Voltage Measurement:	20-300VAC
Frequency Measurement:	1-99 Hz
Connection:	Screw socket
Measurement Accuracy:	Phase Voltages : + / - %1 Generator Frequency : + / - 0.2Hz
Housing:	High temperture proof ABS (UL94-V0, 110 °C)
Protection Class:	IP 52(Front side)
Weight:	230 gr. (aprox.)
Dimensions(GxYxD)	72x72x62 mm
Panel cut out	68x68mm
Mounting Installation	Front panel mounted with metal screw fixings

BOYUTLAR ve MONTAJ

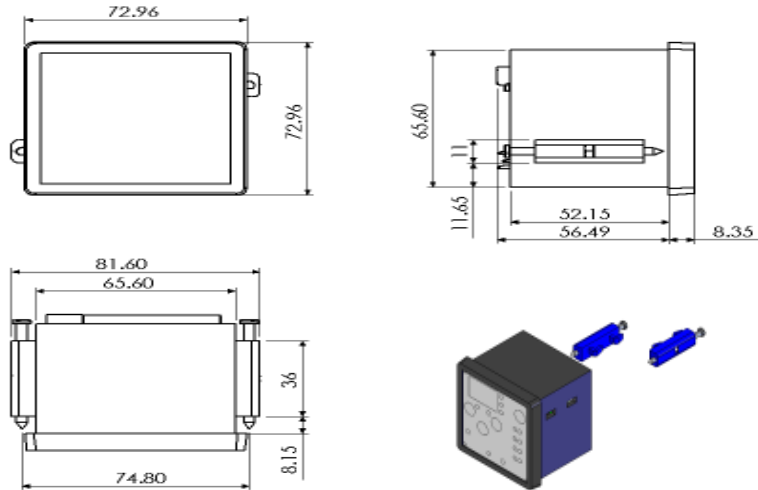

CONNECTIONS

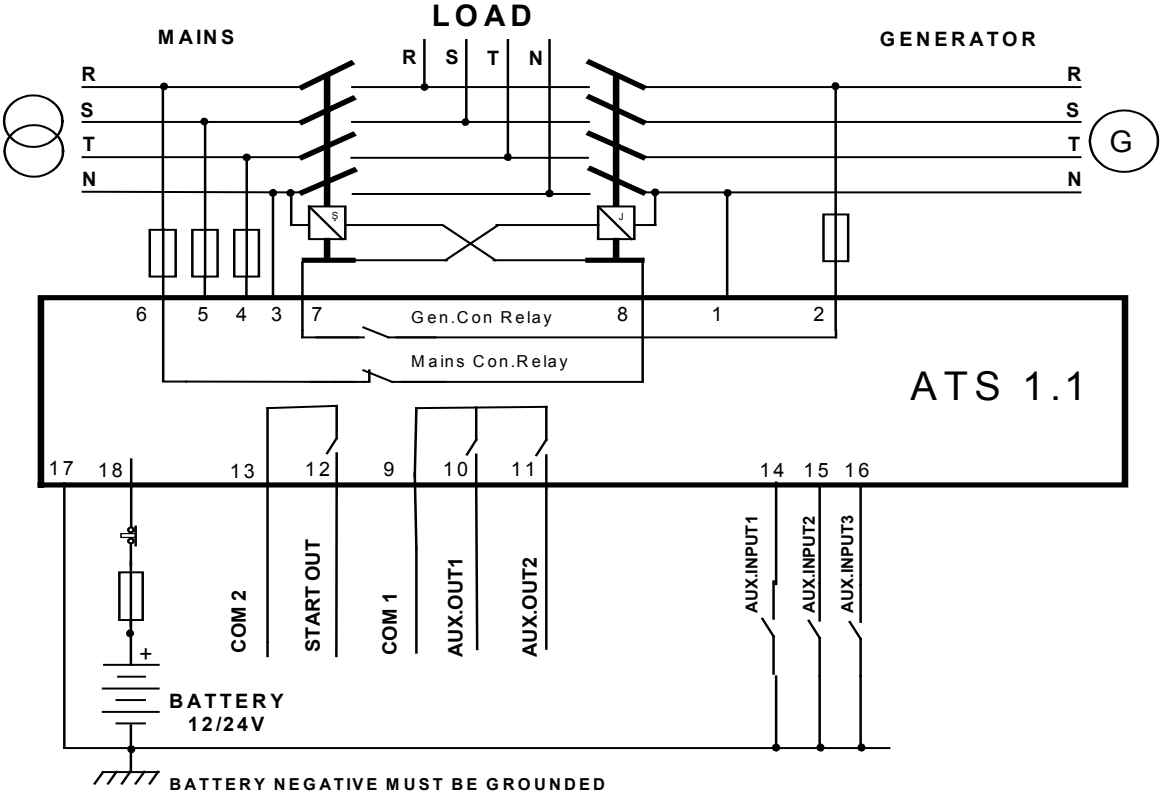

ATS1.1 AUTOMATIC TRAFER SWITCH KONTROL UNIT OPERATORS MANUAL

INTRODUCTION

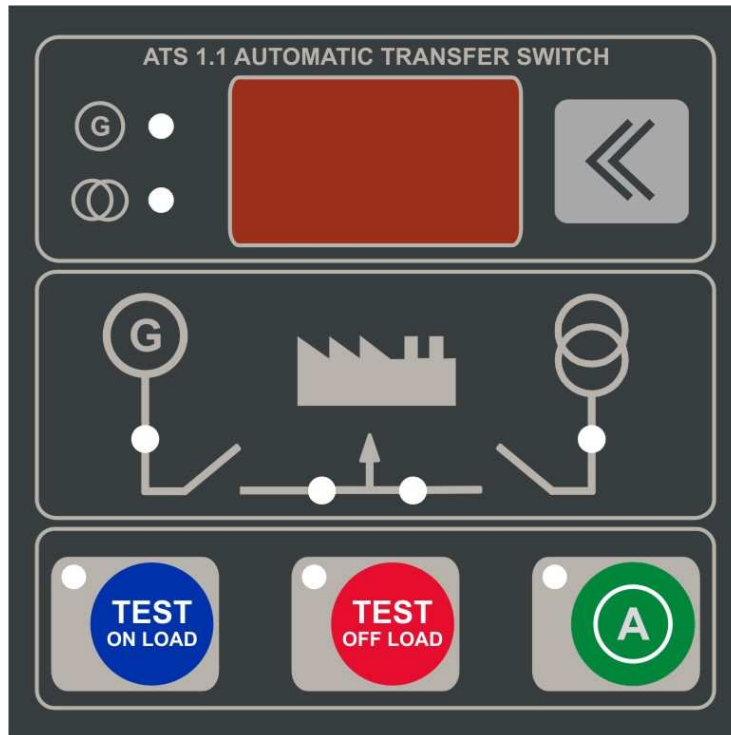

ATS 1.1 automatic transfer unit is a microprocessor based digital unit monitoring the 3 phases of the mains and controls the changeover of mains and generator contactors if a mains failure on any phase is detected. The module offers a very cost effective and space saving solutions as it is able to display all the parameters which are essential for the basic genset transfer control. The module has 3 operation modes. Test on load, test off load and Auto operation modes can be chosen via the push-buttons mounted on the front panel. The 39 parameter settings can also be adjusted from the front panel. So the module can be adapted to all generators without the need of any other unit or module.

Features:

- Micro-processor based design
- Automatic engine starting and stopping commands
- Automatic load transfer
- Configurable via front panel
- Automatic shut down on fault condition
- Test on / off modes
- LED mimic indication
- Operate with cranking dropouts
- 2 configurable auxiliary outputs
- 3 configurable auxiliary inputs

- 3 phase true RMS mains voltage measuring and monitoring
- Mains frequency measuring and monitoring
- Generator phase true RMS voltage measuring and monitoring
- Generator frequency measuring and monitoring
- Digitally adjustable low&high mains and generator voltage limits
- Digitally adjustable generator start command timings
- Digitally adjustable generator overspeed /underspeed limits
- Digitally adjustable mains voltage overspeed/underspeed limits
- Digitally adjustable auxiliary inputs specifications
- Digitally adjustable auxiliary outputs specifications
- Digitally adjustable load transfer timings
- Failure control
- Digitally adjustable warm up/cooling timings
- Digitally adjustable measurement calibrations
- Digital display
- Low cost,small dimensions

Inputs/Outputs:

- 3 phase mains voltage inputs
- Single phase generator voltage input
- 12 / 24 V battery voltage inputs
- Auxiliary1 input
- Auxiliary2 input
- Auxiliary3 input
- Auxiliary1 output
- Auxiliary2 output
- Start command output
- Generator contactor relay output
- Mains contactor relay output

Front View

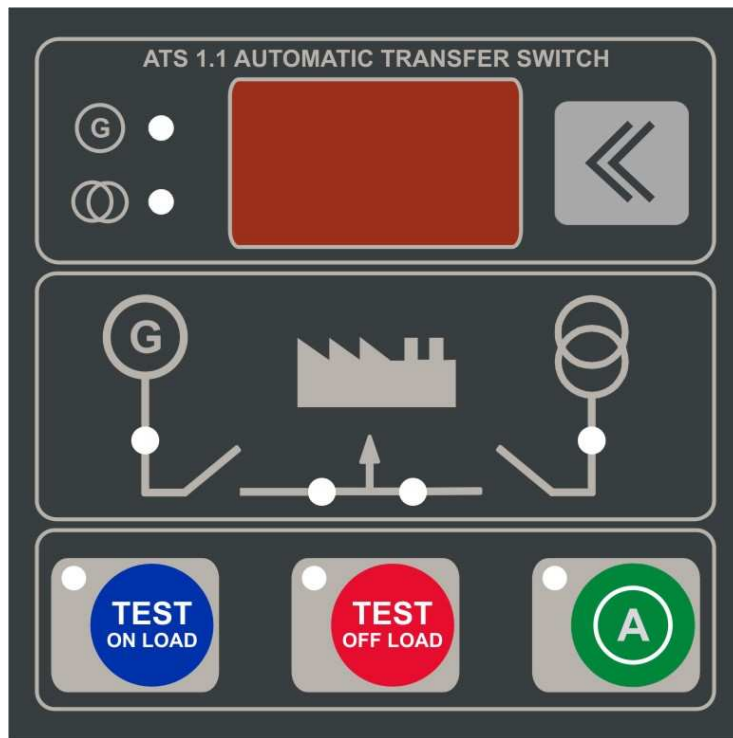

Display: By pressing the menu button in auto ,test on ,test off mode, the voltage and frequency measurements can be displayed on the unit.

- L1-N Mains Voltage
- L2-N Mains Voltage
- L3-N Mains Voltage
- Mains Frequency
- L13 Mains Voltage R-T
- L23 Mains Voltage S-T
- L12 Mains Voltage R-S
- L1-N Generator Voltage
- Generator Frequency

Display Leds:

- G: Indicates the displayed value is a generator voltage or frequency
- M: Indicates the displayed value is a mains voltage or frequency

Automatic Button: Auto button places the unit into automatic mode.

Test On Button: Test on button places the unit into test on mode.

Test Off Button: Test off button places the unit into test off mode.

Off Button (Test Off+Menu button): Off button places the unit into off mode.

Menu Button: By pressing the menu button in auto, test on or test off mode, the voltage and frequency values can be displayed on the unit. If the unit is into off mode, pressing the menu button will place the unit into the password mode. In password mode, the password which will

be adjusted can be chosen with test on(decrease),test off(increase) and auto(changing the digit number) button.After accessing the correct password, by pressing menu button again will place the unit into the menu mode. In menu mode, the menu parameter which will be adjusted can be chosen with the buttons .After selecting the menu parameter, by pressing menu button again will place the unit into the parameter mode. The parameter can be adjusted with the buttons and by pressing menu or off mode , the new parameter is written to the memory .To cancel the menu operations, off button should be pressed.

Mains Contactor Led:Mains contactor LED is activated when the unit energise the mains contactor .

Mains Voltage Led: Mains Voltage LED is activated when the unit detects main voltage in limits.It blinks during the mains voltage safety time after the mains voltage returns.

Generator Contactor Led: Generator contactor LED is activated when the unit energise the generator contactor .

Generator Voltage Led: Generator Voltage LED is activated when the unit detects generator voltage in limits.

Rear View

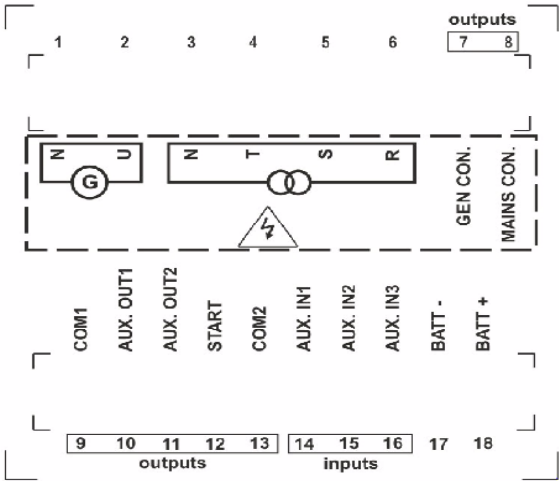

TERMINAL CONNECTIONS

Terminal No:	Description:	Notes:
1	N	Alternator Neutral sensing input
2	U	Alternator R phase voltage sensing input
3	N	Mains Neutral sensing input
4	T	Mains T phase voltage sensing input
5	S	Mains S phase voltage sensing input
6	R	Mains R phase voltage sensing input
7	GEN CON.	Outputs alternator R phase voltage to energise the generator contactor.
8	MAINS CON.	Outputs mains R phase voltage to energise the mains contactor .
9	COM1	Common input for aux output relays

10	AUX.OUT1	Configurable output relay
11	AUX.OUT2	Configurable output relay
12	START	Start command output relay
13	COM2	Common input for start output relay
14	AUX.IN1	Configurable input(negative closing switch input)
15	AUX.IN2	Configurable input(negative closing switch input)
16	AUX.IN3	Configurable input(negative closing switch input)
17	BAT(-)	DC - supply input
18	BAT(+)	DC + supply input

OPERATION MODES

OFF Mode:

The module is placed into off mode by pressing MENU + TEST OFF buttons together. Off mode is used for stopping the engine. If off button (menu+test off buttons) is pressed while the module is in auto, test on or test off modes, the module will de-energise generator contactor output relay if they are energised and if the engine is running on load, the module will allow the alternator to run off load to cool it adequately. When the cooling time is expired, the module will de-energise the start output and the engine is brought to rest.

While the module is in off mode, by pressing the menu button, 39 parameters can be adjusted.

AUTO Mode:

The module is placed into auto mode by pressing auto button. If a mains failure on any phase is detected after the mains failure delay timer expires, the load is switched off from the mains and the ATS unit automatically will issue a start command to the genset controller by using the parameters settings which are adjusted before. When the generator operates within the limits adjusted before, the load is transferred to the generator by the ATS module. When the mains supply has been restored after the mains transition delay timer expires, the ATS module will transfer the load back from the generator to the mains supply and remove start command from the genset controller after cooling time. In case of a failure while operating, the unit will stop the generator automatically. A clear mimic diagram and LEDs provide information about the load status and voltages.

TEST ON Mode :

This is used to manually start the engine on load even the mains voltage is within the limits.

TEST OFF Mode :

This is used to manually start the engine off load even the mains voltage is within the limits.

The load is supplied by the mains but if the mains supply fails, then the load is transferred to the generator automatically.

INPUTS/OUTPUTS

DC Supply Input: Battery + DC supply is connected to BATT+ terminal. Battery – DC supply is connected to BATT- terminal. The modul is protected to reverse connection. 12/24V battery can be connected by using the same terminals.

Alternator Input: Alternator single phase and neutral outputs are connected alternator inputs of the modul. Alternator voltage and frequency are monitored from these inputs.

Mains Input: Mains 3 phase and neutral supply voltage is connected mains inputs of the modul. Mains voltage and frequency are monitored from these inputs. If only one phase of the mains voltage is required to be monitored, other mains voltage inputs of the modul have to be short circuited with the connected phase voltage.

Auxiliary Input 1: Auxiliary input can be configured as Normally Open input and Normally Close input by adjusting P21 number of the parameter. And the function can be configured as unused, remote start on load, remote start off load, mains simulate , mains disable, auto start disable, mains contactor disable, generator contactor disable, C type failure input, D type failure input, E type failure input , F type failure input by adjusting the P20 parameter number. If this input will not be used, it has to be configured as NO(P21) and unused(P20) and leaved empty. It is a negative closing switch.

Auxiliary Input 2: Auxiliary input can be configured as Normally Open input and Normally Close input by adjusting P23 number of the parameter. And the function can be configured as unused, remote start on load, remote start off load, mains simulate , mains disable, auto start disable, mains contactor disable, generator contactor disable, C type failure input, D type failure input, E type failure input , F type failure input by adjusting the P22 parameter number. If this input will not be used, it has to be configured as NO(P23) and unused(P22) and leaved empty. It is a negative closing switch.

Auxiliary Input 3: Auxiliary input can be configured as Normally Open input and Normally Close input by adjusting P25 number of the parameter. And the function can be configured as unused, remote start on load, remote start off load, mains simulate , mains disable, auto start disable, mains contactor disable, generator contactor disable, C type failure input, D type failure input, E type failure input , F type failure input by adjusting the P24 parameter number. If this input will not be used, it has to be configured as NO(P25) and unused(P24) and leaved empty. It is a negative closing switch.

Mains Contactor Relay Output(250VAC 10A): Mains contactor output is used for energising the mains contactor to transfer load to the mains. It outputs R phase of the mains from its normally close terminal.

Generator Contactor Relay Output(250VAC 10A): Generator contactor output is used for energising the generator contactor to transfer load to the generator. It outputs R phase of the generator from its normally open terminal.

Starter Command Relay Output(250VAC 6A): It outputs the signal connected to com2 .It is activated when the modul issues a start command.

Auxiliary Relay Output 1(250VAC 6A): Auxiliary output can be configured as mains failure output, generator failure output, engine running output,generator on load output, mains on load output,auto mode ready output,module is available output, failure output by adjusting the P26 parameter number.By adjusting the P27 parameter number, the auxiliary relay output is configured as normally open output or normally close output. It outputs the signal connected to com1.

Auxiliary Relay Output 2(250VAC 6A): Auxiliary output can be configured as mains failure output, generator failure output, engine running output,generator on load output, mains on load output,auto mode ready output,module is available output, failure output by adjusting the P28 parameter number.By adjusting the P29 parameter number, the auxiliary relay output is configured as normally open output or normally close output. It outputs the signal connected to com1.

FAILURES

Auxiliary inputs can be configured as C type failure input, D type failure input, E type failure input , F type failure input.Failures are self-acknowledge.When the failure conditions are restored and the failure input is de-activated, failures are reset.If the auxiliary failure is adjusted as one of D,E,F type failures, this input has to be de-activated before the ATS modul issues a start command.

C type failure:When the aux failure input is activated, the modul will de-energise generator contactor output relay.But the engine goes on running.When the failure input is de-activated, the modul will energise the generator contactor again.

D type failure:When the aux failure input is activated, the modul will de-energise generator contactor output relay.But the engine goes on running off load until the cooling time expires.When the cooling time expires, the modul will issue stop command to stop the generator.

E type failure:When the aux failure input is activated, the modul will de-energise generator contactor output relay.The modul will issue stop command to stop the generator at the same time.

F type failure:When the aux failure input is activated, the modul will de-energise generator contactor and mains contactor output relays.The modul will issue stop command to stop the generator at the same time.

PROGRAMING PARAMETERS

Moduls are easily programmed and the parameters are displayed and configured by using push-buttons on the front panel. If the unit is off mode, pressing the menu button will place the unit into the password mode. In password mode, the password which will be adjusted can be chosen with test on(decrease), test off(increase) and auto(changing the digit number) button. After accessing the correct password, by pressing menu button again will place the unit into the menu mode. In menu mode, the menu parameter which will be adjusted can be chosen with the buttons. After selecting the menu parameter, by pressing menu button again will place the unit into the parameter mode. The parameter can be adjusted with the buttons and by pressing menu button, the configured value is written to the memory with display flashing 3 times. With the pressing off button, off mode is returned. To cancel the parameter configuration, off button has to be pressed.

If the adjusted password is faulty, faulty message(Err) is displayed. And one of the buttons have to be pressed to place into a operating modes.

If the adjusted parameter is out of limits, faulty message(Err) is displayed for 3 seconds and the parameter have to be adjusted again. To leave from the programming menu, off button(test off+menu button) has to be pressed.

Parameter Number:	Configurable parameter:	Standard Value:	Minimum Value:	Maximum Value:
P0	Customer Code:		0	999
P1	Generator voltage lower limit:	180	50	600
P2	Generator voltage upper limit:	250	50	600
P3	Generator frequency lower limit:	45	10	99
P4	Generator frequency upper limit:	55	10	99
P5	Mains voltage lower limit:	170	50	600
P6	Mains voltage upper limit:	265	50	600
P7	Mains frequency lower limit:	45	10	99
P8	Mains frequency upper limit:	55	10	99
P9	Voltage Histerisis:	10	1	50
P10	Remote Start output delay:	3	0	300
P11	Generator fault control delay:	5	3	300
P12	Mains transition delay:	60	10	300
P13	Mains fault control delay:	3	1	300
P14	Mains contactor delay:	1	0	300
P15	Generator contactor delay:	9	0	300
P16	Engine cooling duration:	60	0	900
P17	Mains Frequency Enable:	1	0	1
P18	Generator Frequency Enable:	1	0	1
P19	Remote Start Output Selection:	0	0	1
P20	Aux Input 1:	8	0	11
P21	Input Configuration:	1	0	1
P22	Aux Input 2:	9	0	11
P23	Input Configuration:	1	0	1
P24	Aux Input 3:	10	0	11
P25	Input Configuration:	1	0	1
P26	Aux Output 1:	3	0	8
P27	Output Configuration:	0	0	1
P28	Aux Output 2:	1	0	8
P29	Output Configuration:	0	0	1
P30	Fault control delay:	8	3	300
P31	Default parameters:	0	0	1
P32	Password:	1	0	999

P33	Power On Operating Mode:	1	0	3
P34	Mains control in off mode:	1	0	1
P35	Calibrations L1	145	10	300
P36	Calibrations L2	145	10	300
P37	Calibrations L3	145	10	300
P38	Calibrations GEN	145	10	300

DESCRIPTION OF PARAMETERS

No	Parameter	Description
Parameters		
P00	Costemer Code:	All customers have their own code.This parameter shows this code.It can not be configured.
P01	Generator Voltage Lower Limit:	If the voltage of the generator output falls below generator voltage lower limit a shutdown is initiated. The modul will indicate voltage failure.
P02	Generator Voltage Upper Limit:	If the voltage of the generator output exceeds generator voltage upper limit a shutdown is initiated. The modul will indicate voltage failure
P03	Generator Frequency Lower Limit:	If the frequency of the generator output falls below generator frequency lower limit a shutdown is initiated.
P04	Generator Frequency Upper Limit:	If the frequency of the generator output exceeds generator frequency upper limit a shutdown is initiated.
P05	Mains Voltage Lower Limit:	If the voltage of the mains falls below mains voltage lower limit the modul will indicate mains failure.
P06	Mains Voltage Upper Limit	If the voltage of the mains exceeds mains voltage upper limit the modul will indicate mains failure.
P07	Mains Frequency Lower Limit:	If the frequency of the mains voltage falls below mains frequency lower limit , the modul will indicate mains failure.
P08	Mains Frequency Upper Limit:	If the frequency of the mains voltage exceeds mains frequency upper limit , the modul will indicate mains failure.
P09	Voltage Histerisis:	If the voltage of the mains exceeds mains voltage lower limit + voltage histerisis ,the modul will accept the mains normal.
P10	Remote Start Output Delay:	If there is any failure on any phase of the mains voltage , the modul will issue a start command after this timer expires.
P11	Generator fault control delay:	If the generator voltage or frequency is out of acceptable limits, the modul will wait during the generator fault control delay timer before indicating any alarm condition.This parameter is useful during instant load changing.
P12	Mains transition delay:	When the mains returns within the limits,the module will first initiate mains transition delay timer to ensure that it is safe to stop the generator. If the mains voltage has no failure after this timer expires,the modul will initiate mains contactor delay timer.
P13	Mains fault control delay:	The modul accepts mains failure if the failure is active

		during the mains fault control delay timer. After this timer expires, the modul accepts a mains failure.
P14	Mains contactor delay:	If the mains voltage has no failure after the mains transition delay timer expires, the modul will initiate mains contactor delay timer. When the timer expires, the modul will energise the mains contactor output.
P15	Generator contactor delay:	After the starter motor is detected starting, the generator contactor delay timer is activated. After this timer expires, the modul will energise the generator contactor if there is no failure with the generator signals. This parameter must be adjusted bigger than P30 parameter.
P16	Engine cooling duration:	After the modul de-energise the generator contactor output, the module will then initiate its cooling timer. This allows the engine to run off load to ensure that it has adequately cooled before being brought to a standstill.
P17	Mains Frequency Enable:	0-(No): This parameter is selected if the mains frequency is inactive while the modul decides if there is any mains fault. But the modul goes on indicate the mains frequency. 1-(Yes): This parameter is selected if the mains frequency is active while the modul decides if there is a mains fault.
P18	Generator Frequency Enable:	0-(No): This parameter is selected if the generator frequency is inactive while the modul decides if there is a generator fault. But the modul goes on indicate the generator frequency. 1-(Yes): This parameter is selected if the generator frequency is active while the modul decides if there is a generator fault.
P19	Remote Start Output Selection:	Remote start output function can be configured as one of the following: 0-(NO): Remote Start output relay is energised to issue start command. 1-(NC): Remote Start output relay is de-energised to issue start command.
P20	Auxiliary Input 1:	Auxiliary input function can be configured as one of the following: 0-Unused: This parameter is selected if the aux input function isn't used. 1-Remote Start On Load: When the aux input is activated, the modul issues start command and takes load whether the mains voltage is within limits. This function is enabled in auto mode. 2-Remote Start Off Load: When the aux input is activated, the modul issues start command but doesn't take load until there is a mains failure. This function is enabled in auto mode. 3-Mains Simulate: When the aux input is activated, the mains voltage is accepted normal in spite of a mains failure. This function is enabled in auto mode. 4-Mains Failure: When the aux input is activated, the mains voltage is accepted fault. This function is enabled in auto

		<p>mode.</p> <p>5-Auto Start Disable:When the aux input is activated ,the modul is prevented to issue start command.This function is enabled in auto mode.</p> <p>6-Mains Contactor Disable:When the aux input is activated, the modul is disabled to take load to the mains contactor.This function is enabled in auto mode.</p> <p>7-Generator Contactor Disable:When the aux input is activated, the modul is disabled to take load to the generator contactor.This function is enabled in auto mode.</p> <p>8-C type Failure: When the aux input is activated, the modul accepts the signal as a C type failure.This function is enabled in all modes.</p> <p>9-D type Failure: When the aux input is activated, the modul accepts the signal as a D type failure. This function is enabled in all modes.</p> <p>10-E type Failure: When the aux input is activated, the modul accepts the signal as a E type failure. This function is enabled in all modes.</p> <p>11-F type Failure: When the aux input is activated, the modul accepts the signal as a F type failure. This function is enabled in all modes.</p>
P21	Input Configuration:	<p>Auxiliary input can be configured as one of the following:</p> <p>0-NC(Normally Closed): Auxiliary input is configured to activate by disconnecting the input to the battery negative voltage.</p> <p>1-NO(Normally Open): Auxiliary input is configured to activate by connecting the input to the battery negative voltage.</p>
P22	Auxiliary Input 2:	<p>Auxiliary input function can be configured as one of the following:</p> <p>0-Unused:This parameter is selected if the aux input function isn't used.</p> <p>1-Remote Start On Load: When the aux input is activated, the modul issues start command and takes load whether the mains voltage is within limits.This function is enabled in auto mode.</p> <p>2-Remote Start Off Load: When the aux input is activated, the modul issues start command but doesn't take load until there is a mains failure. This function is enabled in auto mode.</p> <p>3-Mains Simulate:When the aux input is activated ,the mains voltage is accepted normal. This function is enabled in auto mode.</p> <p>4-Mains Failure: When the aux input is activated ,the mains voltage is accepted fault. This function is enabled in auto mode.</p> <p>5- Auto Start Disable:When the aux input is activated ,the modul is prevented to issue start command.This function is enabled in auto mode.</p>

		<p>6-Mains Contactor Disable:When the aux input is activated, the modul is disabled to take load to the mains contactor.This function is enabled in auto mode.</p> <p>7-Generator Contactor Disable:When the aux input is activated, the modul is disabled to take load to the generator contactor.This function is enabled in auto mode.</p> <p>8-C type Failure: When the aux input is activated, the modul accepts the signal as a C type failure.This function is enabled in all modes.</p> <p>9-D type Failure: When the aux input is activated, the modul accepts the signal as a D type failure. This function is enabled in all modes.</p> <p>10-E type Failure: When the aux input is activated, the modul accepts the signal as a E type failure. This function is enabled in all modes.</p> <p>11-F type Failure:When the aux input is activated, the modul accepts the signal as a F type failure. This function is enabled in all modes.</p>
P23	Input Configuration:	<p>Auxiliary input can be configured as one of the following:</p> <p>0-NC(Normally Closed): Auxiliary input is configured to activate by disconnecting the input to the battery negative voltage.</p> <p>1-NO(Normally Open): Auxiliary input is configured to activate by connecting the input to the battery negative voltage.</p>
P24	Auxiliary Input 3:	<p>Auxiliary input function can be configured as one of the following:</p> <p>0-Unused:This parameter is selected if the aux input function isn't used.</p> <p>1-Remote Start On Load: When the aux input is activated, the modul issues start command and takes load whether the mains voltage is within limits.This function is enabled in auto mode.</p> <p>2-Remote Start Off Load: When the aux input is activated, the modul issues start command but doesn't take load until there is a mains failure. This function is enabled in auto mode.</p> <p>3-Mains Simulate:When the aux input is activated ,the mains voltage is accepted normal. This function is enabled in auto mode.</p> <p>4-Mains Failure: When the aux input is activated ,the mains voltage is accepted fault. This function is enabled in auto mode.</p> <p>5- Auto Start Disable:When the aux input is activated ,the modul is prevented to issue start command.This function is enabled in auto mode.</p> <p>6-Mains Contactor Disable:When the aux input is activated, the modul is disabled to take load to the mains contactor.This function is enabled in auto mode.</p> <p>7-Generator Contactor Disable:When the aux input is</p>

		<p>activated, the modul is disabled to take load to the generator contactor.This function is enabled in auto mode.</p> <p>8-C type Failure: When the aux input is activated, the modul accepts the signal as a C type failure.This function is enabled in all modes.</p> <p>9-D type Failure: When the aux input is activated, the modul accepts the signal as a D type failure. This function is enabled in all modes.</p> <p>10-E type Failure: When the aux input is activated, the modul accepts the signal as a E type failure. This function is enabled in all modes.</p> <p>11-F type Failure:When the aux input is activated, the modul accepts the signal as a F type failure. This function is enabled in all modes.</p>
P25	Input Configuration:	<p>Auxiliary input can be configured as one of the following:</p> <p>0-NC(Normally Closed): Auxiliary input is configured to activate by disconnecting the input to the battery negative voltage.</p> <p>1-NO(Normally Open):Auxiliary input is configured to activate by connecting the input to the battery negative voltage.</p>
P26	Auxiliary Output 1:	<p>Auxiliary output function can be configured as one of the following:</p> <p>0-Unused:Auxiliary output is never activated .</p> <p>1-Mains Failure: Auxiliary output is activated when there is a mains failure.</p> <p>2-Generator Failure:Auxiliary output is activated when there is a generator failure.</p> <p>3-Engine Running:Auxiliary output is activated when the modul detects engine running.</p> <p>4-Generator On Load:Auxiliary output is activated when the generator contactor takes load.</p> <p>5-Mains On Load:Auxiliary output is activated when the mains contactor takes load.</p> <p>6-Automatic Mode Ready:Auxiliary output is activated when the modul is in auto mode.</p> <p>7-Module Energised: Auxiliary output is activated when the module is energised.</p> <p>8-Alarm Output:Auxiliary output is activated when there is a failure.</p>
P27	Aux Output Configuration:	<p>Aux output function can be configured as one of the following:</p> <p>0-(NO):Aux output relay is energised when the output is activated.</p> <p>1-(NC): Aux output relay is de-energised when the output is activated.</p>
P28	Auxiliary Output 2:	<p>Auxiliary output function can be configured as one of the following:</p> <p>0-Unused:Auxiliary output is never activated .</p> <p>1-Mains Failure: Auxiliary output is activated when there</p>

		<p>is a mains failure.</p> <p>2-Generator Failure:Auxiliary output is activated when there is a generator failure.</p> <p>3-Engine Running:Auxiliary output is activated when the modul detects engine running.</p> <p>4-Generator On Load:Auxiliary output is activated when the generator contactor takes load.</p> <p>5-Mains On Load:Auxiliary output is activated when the mains contactor takes load.</p> <p>6-Automatic Mode Ready:Auxiliary output is activated when the modul is in auto mode.</p> <p>7-Module Energised: Auxiliary output is activated when the module is energised.</p> <p>8-Alarm Output:Auxiliary output is activated when there is a failure.</p>
P29	Aux Output Configuration:	<p>Aux output function can be configured as one of the following:</p> <p>0-(NO):Aux output relay is energised when the output is activated.</p> <p>1-(NC): Aux output relay is de-energised when the output is activated.</p>
P30	Fault control delay:	<p>If the engine start is successful,the fault control delay timer is activated. This timer allows Under/over speed, Under/over volts to stabilise without triggering the fault. Once the engine is running and the fault control delay timer has expired, full fault protection is made available</p>
P31	Default parameters:	1: All parameters return to the factory defaults.
P32	Password:	Password is used to change the parameters.
P33	Power On Operating Mode:	<p>0-Power on operating mode is selected as OFF mode.</p> <p>1-Power on operating mode is selected as AUTO mode.</p> <p>2-Power on operating mode is selected as TEST ON mode.</p> <p>3-Power on operating mode is selected as TEST OFF mode.</p>
P34	Mains control in off mode:	<p>0-No: The modul control the mains 3 phase voltage. If the mains voltage has no failure, the modul will supply the load with mains voltage in off mode.If there is any failure in any phase of the mains voltage the modul switches off the load from the mains voltage.</p> <p>1-Yes: The modul doesn't control the mains voltage in off mode.It always supplies the load with the R phase of the mains voltage.</p>
P35	Calibrations L1	Mains line R voltage calibration.
P36	Calibrations L2	Mains line S voltage calibration.
P37	Calibrations L3	Mains line T voltage calibration.
P38	Calibrations GEN	Generator R voltage calibration.

SPECIFICATIONS

DC Supply:	9-35VDC 20mA (stop mode) 70mA (auto mode) 110mA(maximum current)
Operating Temperature:	-10°C / +70°C
Relative Humidity:	%10-%95 non-condensing
Relay Outputs:	Start and auxiliary outputs 6A/12-24VDC Generator and mains contactor outputs 10A / 250VAC
Voltage Measurement:	20-300VAC
Frequency Measurement:	1-99 Hz
Connection:	Screw socket
Measurement Accuracy:	Phase Voltages : + / - %1 Generator Frequency : + / - 0.2Hz
Housing:	High temperture proof ABS (UL94-V0, 110 ⁰ C)
Protection Class:	IP 52(Front side)
Weight:	230 gr. (aprox.)
Dimensions(GxYxD)	72x72x62 mm
Panel cut out	68x68mm
Mounting Installation	Front panel mounted with metal screw fixings

BOYUTLAR ve MONTAJ

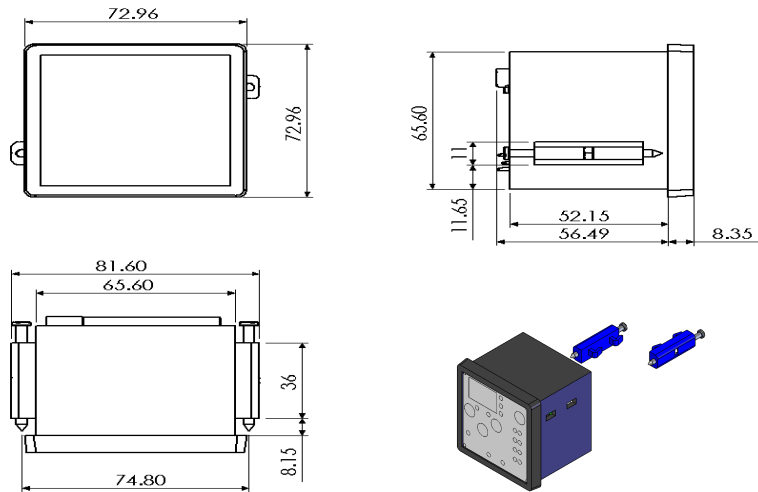

CONNECTIONS

